

World-class solutions  
in medical-grade materials.



**FORT WAYNE METALS**

Turning knowledge into solutions.

## Table of Contents

### Materials

#### Stainless Steels

302 .....	1.1
304LV .....	1.2
304V .....	1.3
316LVM .....	1.4
Custom 455° .....	1.5

#### High Performance Alloys

FWM 1058° .....	2.1
MP35N° .....	2.2
35N LT° .....	2.3
L-605 .....	2.4
FWM™ 1537 .....	2.5

#### Titanium and Titanium Alloys

Unalloyed Commercially Pure (CP) Titanium .....	3.1
Ti 6Al-4V ELI .....	3.2

**Nitinol** .....

**DFT® Wire** .....

### Products and Capabilities

<b>Flat Wire</b> .....	6.1
<b>Shaped Wire</b> .....	6.2
<b>Strands and Cables</b> .....	6.3
<b>HHS® Tube</b> .....	6.4
<b>SLT® Wire</b> .....	6.5
<b>NDR® Wire</b> .....	6.6
<b>Laser Ablation</b> .....	6.7
<b>Packaging and Spooling</b> .....	6.8

<b>Biomedical Coatings</b> .....	7.1
<b>PTFE Coatings</b> .....	7.2

#### Conversion Chart

Stainless Steel and other Wire Materials .....	8.1
---	-----

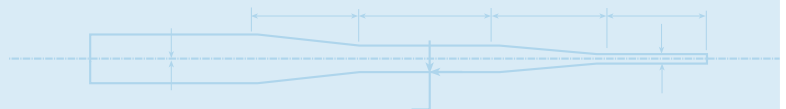

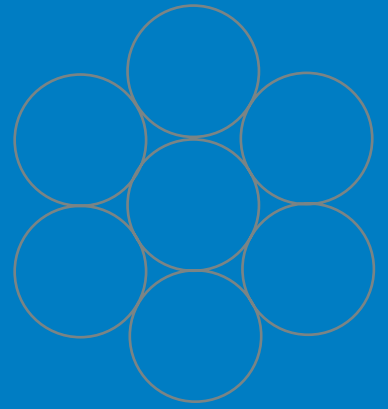

## Customer Commitment

As a leading manufacturer of medical-grade materials, we fully support our customers' requirements for quality, service, reliability, dependability and R&D projects. We are FDA registered and ISO 13485, ISO 9001 and AS 9100 certified. We are fully capable of statistical process controls and just-in-time inventory scheduling. At Fort Wayne Metals we're committed to working with each of our customers to ensure that we meet their specific needs as we turn knowledge into solutions.



## AVAILABLE ALLOYS

Nitinol (Binary & Ternary)  
CP Ti Gr. 1  
CP Ti Gr. 2  
CP Ti Gr. 3  
CP Ti Gr. 4  
Ti 6Al-4V ELI  
Ti 6Al-7Nb  
Ti 3Al-2.5V  
Ti-Beta 3  
Ti-Beta C  
302  
304V  
304LV  
316LVM  
DFT® (Composites)  
35N LT®  
MP35N®  
L-605 (HAYNES® 25)  
DBS®  
FWM 1058®  
FWM™ 1537  
HASTELLOY® C-276 Alloy  
HAYNES® 214™  
17-7PH®  
CUSTOM 455®, 465®, 470®  
WASPALOY®  
22Cr-13Ni-5Mn

Not all types stocked. Other alloys available.

## PRODUCT USES

Bioconductors  
Neuro Stimulation  
Catheter Reinforcement  
Orthopaedics  
Orthodontics  
Surgical Needles  
Surgical Staples & Clips  
Suture Wire  
Stents  
Guidewires & Delivery Systems  
Endoscopy

**And other demanding medical products**

FWM is a trademark and DBS, DFT, 35N LT, FWM 1058 Alloy, SLT and HHS are registered trademarks of Fort Wayne Metals Research Products Corporation.  
17-7PH is a registered trademark of AK Steel, Inc.  
CUSTOM 455 and Conichrome are registered trademarks of Carpenter Technologies, Inc.  
HAYNES, HASTELLOY and 214 are registered trademarks of Haynes International, Inc.  
MP35N is a registered trademark of SPS Technologies.  
WASPALOY is a registered trademark of United Technologies Corporation.  
Phynox is a registered trademark of Imphy SA, Paris, France.  
Elgiloy is a registered trademark of Elgiloy Limited Partnership, Elgin, IL.

## PROCESSING CAPABILITIES

Diamond Drawing  
Strand Annealing  
Custom Spooling  
Flat Drawing  
Flat Rolling  
Custom Stranding and Cabling  
Straightening and Cutting  
Centerless Grinding and Polishing  
Coatings: Dielectric Insulation (ETFE, PFA, FEP)  
Lubricious (LubriSkin™, DuraSkin™)



## PROPERTIES DATA

The data and information provided are based on work conducted principally by Fort Wayne Metals Research Products Corp. and occasionally supplemented by information from the open literature, and are believed to be reliable. However, we do not make any warranty or assume any legal liability or responsibility for its accuracy, completeness or usefulness, nor do we represent that its use would not infringe upon private rights. Any suggestions as to uses and applications for specific alloys are opinions only and Fort Wayne Metals Research Products Corp. makes no warranty of results to be obtained in any particular situation. For specific concentrations of elements present in a particular product and a discussion of the potential health effects thereof, refer to the Material Safety Data Sheet supplied by Fort Wayne Metals Research Products Corp.

© 2011 Fort Wayne Metals Research Products Corp.

# 302

## Melt Practice

We offer this high quality austenitic stainless steel for spring applications. To keep costs at a minimum this alloy is supplied from an electric-arc air melted process. Localized variations in chemistry can cause slight changes in ultimate tensile strength when drawing to fine wire.

### Typical Chemistry

	FWM Avg. Wt. %	ASTM A313
Carbon	0.10	0.12
Manganese	1.11	2.00
Phosphorus	0.023	0.045
Sulfur	0.002	0.030
Silicon	0.52	1.00
Chromium	18.60	17.0-19.0
Nickel	8.40	8.0-10.0
Molybdenum	0.32	-
Copper	0.36	-
Nitrogen	0.03	0.10
Cobalt	0.16	-
Iron	balance	balance

FWM chemistry is for reference only, and is not to be used for specification purposes.

### Physical Properties

Density	0.285 lbs/in <sup>3</sup>
Modulus of Elasticity	28.0 x 10 <sup>6</sup> psi
Electrical Resistivity	720 µohms-mm
Thermal Conductivity	16.3 W/m K (100°C)

## Thermal Treatment

In wire form, cold worked 302 will gain tensile strength when stress relieved at 350-427°C for 4-6 hours. A reducing atmosphere is preferred, but inert gas can be used. 302 will fully anneal at 1010-1121°C in just a few minutes. There is a carbide precipitation phenomenon that occurs between 427 and 899°C that reduces the corrosion resistance of the alloy. American Society for Testing Materials (ASTM) has described a test method to ensure the alloy has not been damaged.

## Applications

302 alloy is the same as 304 alloy except for the 0.12% carbon maximum. In 304 the maximum carbon is 0.08%. Technically, all 304 alloy meets the requirements of 302 alloy, but not all 302 can meet 304 chemistry. Practically, this means in general 302 is harder than 304 with the same amount of cold work. End uses for 302 include: stylets, catheters, guidewires, springs and needles.

### Mechanical Properties

% Cold Work	Y.S. (psi)	U.T.S. (psi)	% Elongation (10" gage length)
0%	49,000	106,000	48%
20%	125,000	147,000	9.8%
37%	169,000	189,000	3.2%
50%	196,000	220,000	2.6%
60%	222,000	244,000	2.2%
68%	243,000	273,000	2.1%
75%	251,000	289,000	2.4%
80%	282,000	309,000	2.2%
84%	295,000	327,000	2.2%
87%	300,000	332,000	2.3%
90%	319,000	345,000	2.2%
92%	322,000	371,000	2.5%

Values are typical and may not represent all diameters. Test method will affect results.

## Surface Conditions

Stainless steels develop a highly polished appearance as they are drawn to fine diameters. Surface roughness can be less than 5 microinches RMS when processed using single crystal natural diamond dies and measured with a profilometer. Diameters over .040" are finished with polycrystalline dies and exhibit a rougher surface than natural diamond dies. Diameters over 0.100" have an even rougher surface because they are drawn with carbide dies. Additional finish treatments can enhance the surface of the wire.

# 304LV

## Melt Practice

This austenitic stainless steel is initially electric-arc melted. Then as a refinement to the purity and homogeneity of the metal, 304LV is Vacuum Arc Remelted (VAR). This process yields a more uniform chemistry with minimal voids and contaminants. The "L" means low carbon as compared to 304V.

## Typical Chemistry

	FWM Avg. Wt. %
Carbon	0.018
Manganese	1.280
Phosphorus	0.018
Sulfur	0.005
Silicon	0.46
Chromium	18.55
Nickel	9.87
Molybdenum	0.24
Copper	0.24
Nitrogen	0.042
Cobalt	0.13
Iron	balance

FWM chemistry is for reference only, and is not to be used for specification purposes.

## Physical Properties

Density	0.285 lbs/in <sup>3</sup>
Modulus of Elasticity	28.0 x 10 <sup>6</sup> psi
Electrical Resistivity	720 µohms-mm
Thermal Conductivity	16.3 W/m K (100°C)

## Thermal Treatment

A reducing atmosphere is preferred for thermal treatment but inert gas can be used. 304LV will fully anneal at 1010-1121°C in just a few minutes. The precipitation of carbides that decreases corrosion resistance in other 300 series alloys is controlled by a reduced carbon content in 304LV.

## Applications

The chemistry of 304LV makes it less susceptible to sensitization. (Sensitization is the reduction in a material's corrosion resistance due to exposure to elevated temperatures.) Because of this feature, 304LV is recommended when exposure to 427-649°C is likely. End uses include: catheters, guidewires, small parts made from straightened and cut wire and orthodontic uses.

## Mechanical Properties

% Cold Work	Y.S. (psi)	U.T.S. (psi)	% Elongation (10" gage length)
0%	48,000	90,000	40%
20%	81,500	106,000	27%
37%	116,000	147,000	5.9%
50%	147,000	173,000	3.2%
60%	167,000	191,000	2.8%
68%	158,000	206,000	2.8%
75%	183,000	217,000	2.7%
80%	203,000	223,000	2.6%
84%	211,000	232,000	2.5%
90%	220,000	240,000	2.5%
93%	248,000	270,000	2.5%
95%	258,000	281,000	3.1%

Values are typical and may not represent all diameters. Test method will affect results.

## Surface Conditions

Stainless steels develop a highly polished appearance as they are drawn to fine diameters. Surface roughness can be less than 5 microinches RMS when processed using single crystal natural diamond dies and measured with a profilometer. Diameters over .040" are finished with polycrystalline dies and exhibit a rougher surface than natural diamond dies. Diameters over 0.100" have an even rougher surface because they are drawn with carbide dies. Additional finish treatments can enhance the surface of the wire.

# 304V

## Melt Practice

This austenitic stainless steel is initially electric-arc melted. Then as a refinement to the purity and homogeneity of the metal, 304V is Vacuum Arc Remelted (VAR). This process yields a more uniform chemistry with minimal voids and contaminants.

### Typical Chemistry

	FWM Avg. Wt. %	ASTM A313
Carbon	0.073	0.08
Manganese	1.310	2.00
Phosphorus	0.021	0.045
Sulfur	0.001	0.030
Silicon	0.700	1.00
Chromium	18.58	18.0-20.0
Nickel	8.65	8.0-10.5
Molybdenum	0.16	-
Copper	0.17	-
Nitrogen	0.034	0.10
Cobalt	0.10	-
Iron	balance	balance

FWM chemistry is for reference only, and is not to be used for specification purposes.

### Physical Properties

Density	0.286 lbs/in <sup>3</sup>
Modulus of Elasticity	28.5 x 10 <sup>6</sup> psi
Electrical Resistivity	720 µohms-mm
Thermal Conductivity	16.36 W/m K (100°C)

## Thermal Treatment

In wire form, 304V will gain tensile strength when stress relieved at 350-427°C. A reducing atmosphere is preferred but inert gas can be used. 304V will fully anneal at 1010-1121°C in just a few minutes. There is a carbide precipitation phenomenon that occurs between 427 and 899°C that reduces the corrosion resistance of the alloy. American Society for Testing Materials has described a test method to ensure the alloy has not been damaged.

## Applications

This alloy is the most popular for medical appliances. The ease of joining with solder or welding, combined with excellent strength, makes it desirable. This alloy is also one of the least expensive medical materials. Some examples of end products are stylets, catheters, guidewires, springs and needles. Fort Wayne Metals routinely makes cables, strands, flat wire and shapes from this alloy.

### Mechanical Properties

% Cold Work	Y.S. (psi)	U.T.S. (psi)	% Elongation (10" gage length)
0%	50,000	107,000	41%
20%	70,000	140,000	14%
37%	90,000	184,000	4%
50%	140,000	208,000	3%
60%	160,000	229,000	2.6%
68%	180,000	247,000	2.7%
75%	200,000	265,000	2.6%
80%	215,000	272,000	2.9%
84%	230,000	289,000	2.5%
90%	245,000	306,000	2.6%
93%	250,000	316,000	2.7%
95%	280,000	334,000	2.6%

Values are typical and may not represent all diameters. Test method will affect results.

## Surface Conditions

Stainless steels develop a highly polished appearance as they are drawn to fine diameters. Surface roughness can be less than 5 microinches RMS when processed using single crystal natural diamond dies and measured with a profilometer. Diameters over .040" are finished with polycrystalline dies and exhibit a rougher surface than natural diamond dies. Diameters over 0.100" have an even rougher surface because they are drawn with carbide dies.

# 316LVM

## Melt Practice

This austenitic stainless steel is initially electric-arc melted. Then as a refinement to the purity and homogeneity of the metal, 316LVM is Vacuum Arc Remelted (VAR). This process yields a more uniform chemistry with minimal voids and contaminants. 316LVM is unique nomenclature for Fort Wayne Metals. This alloy meets the requirements of 316LS.

## Typical Chemistry

	FWM Avg. Wt. %	ASTM F138
Carbon	0.023	0.030
Manganese	1.84	2.00
Phosphorus	0.014	0.025
Sulfur	0.001	0.010
Silicon	0.37	0.75
Chromium	17.57	17.00-19.00
Nickel	14.68	13.00-15.00
Molybdenum	2.79	2.25-3.00
Nitrogen	0.03	0.10
Copper	0.03	0.50
Iron	balance	balance

FWM chemistry is for reference only, and is not to be used for specification purposes.

## Physical Properties

Density	0.287 lbs/in <sup>3</sup>
Modulus of Elasticity	27.9 x 10 <sup>6</sup> psi
Electrical Resistivity	740 µohms-mm
Thermal Conductivity	16.3 W/m K (100°C)

## Thermal Treatment

A reducing atmosphere is preferred for thermal treatment, but inert gas can be used. 316LVM will fully anneal at 1010-1121°C in just a few minutes. The precipitation of carbides that decreases corrosion resistance in other 300 series alloys is controlled by a reduced carbon content in 316LVM.

## Applications

316LVM material has been used for permanent implants for many years. The corrosion resistance in the annealed condition is good. Many studies for new alloys use 316LVM as a reference. This stainless steel has good ductility in the cold worked condition. Applications include: suture wire, orthopaedic cables, skin closure staples, catheters, stylets, bone pins and many small machined parts.

## Mechanical Properties

% Cold Work	Y.S. (psi)	U.T.S. (psi)	% Elongation (10" gage length)
0%	45,000	91,000	42%
20%	110,000	123,000	8%
37%	145,000	160,000	2.5%
50%	161,000	176,000	2.2%
60%	170,000	191,000	2.1%
68%	176,000	203,000	2.5%
75%	191,000	218,000	2.6%
80%	186,000	217,000	2.6%
84%	202,000	227,000	2.6%
90%	205,000	238,000	2.6%
93%	212,000	239,000	2.6%
95%	213,000	246,000	2.8%

Values are typical and may not represent all diameters. Test method will affect results.

## Surface Conditions

Stainless steels develop a highly polished appearance as they are drawn to fine diameters. Surface roughness can be less than 5 microinches RMS when processed using single crystal natural diamond dies and measured with a profilometer. Diameters over .040" are finished with polycrystalline dies and exhibit a rougher surface than natural diamond dies. Diameters over 0.100" have an even rougher surface because they are drawn with carbide dies. Additional finish treatments can enhance the surface of the wire.

# Custom 455®

## Melt Practice

Alloy 455 is an alloy melted by several sources. Custom 455 is a trademarked name of Carpenter Specialty Alloys. It is a martensitic age-hardenable stainless steel that offers a unique set of qualities. This alloy is double vacuum-melted using a Vacuum Induction Melt (VIM) followed by a Vacuum Arc Remelt (VAR).

## Typical Chemistry

	FWM Avg. Wt. %	AMS 5617 #1
Carbon	0.008	0.03
Manganese	0.05	0.50
Silicon	0.07	0.50
Phosphorus	0.006	0.015
Sulfur	0.003	0.015
Chromium	11.27	11.0-12.5
Nickel	8.22	7.50-9.50
Titanium	1.14	0.90-1.40
Copper	2.13	1.50-2.50
Molybdenum	0.07	0.50
Columbium	0.25	0.50
Nitrogen	0.003	0.015
Iron	balance	balance

FWM chemistry is for reference only, and is not to be used for specification purposes.

## Physical Properties

Density	0.280 lbs/in <sup>3</sup>
Modulus of Elasticity	29.0 x 10 <sup>6</sup> psi
Electrical Resistivity	758 μohms-mm
Thermal Conductivity	18.0 W/m K (100°C)

## Thermal Treatment

A reducing atmosphere is preferred for thermal treatment, but inert gas can be used. Alloy 455 will fully anneal at 950-980°C in just a few minutes. Alloy 455 can minimally age harden with a loss in ductility when held for prolonged periods at 370-540°C. Original hardness can be restored by heating at 590°C.

## Applications

Alloy 455 has the advantage of allowing parts fabrication in the more easily worked as-delivered state, after which heat treatment can develop a much higher ultimate tensile strength. Unlike many other heat treatable alloys, Alloy 455 has good oxidation resistance at room temperature. Primary end applications are: needles, stylets, pins and springs.

## Mechanical Properties

% Cold Work	U.T.S. (psi)	% Elongation (10" gage length)
0%	145,000	6.3%
20%	153,000	5.7%
37%	161,000	3.8%
50%	165,000	3.5%
60%	173,000	4.6%
68%	185,000	2.4%
75%	190,000	2.5%
80%	193,000	2.6%
84%	199,000	2.6%
87%	210,000	2.2%
90%	220,000	2.5%
92%	230,000	2.4%

Values are typical and may not represent all diameters. Test method will affect results.

## Surface Conditions

Stainless steels develop a highly polished appearance as they are drawn to fine diameters. Surface roughness can be less than 5 microinches RMS when processed using single crystal natural diamond dies and measured with a profilometer. Diameters over .040" are finished with polycrystalline dies and exhibit a rougher surface than natural diamond dies. Diameters over 0.100" have an even rougher surface because they are drawn with carbide dies. Additional finish treatments can enhance the surface of the wire.

# FWM 1058<sup>®</sup>

## General

FWM 1058, Conichrome<sup>®</sup>, Phynox<sup>®</sup> and Elgiloy<sup>®</sup> are trademark names for the cobalt-chromium-nickel-molybdenum-iron alloy specified by ASTM F 1058 and ISO 5832-7. Batelle Laboratories originally developed the alloy for making watch springs, and it was patented in 1950.

As demonstrated in the table below, the current FWM 1058 melt specification, is equivalent to Conichrome, Phynox and Elgiloy. The alloy is first melted using Vacuum Induction Melting (VIM) techniques. A secondary melt operation, Electro Slag Remelt (ESR), is then employed to further remove impurities and improve overall homogeneity.

FWM 1058 derives its maximum properties from a combination of cold work and thermal processing, and is not a true precipitation-hardening alloy since the response to heat treatment is a function of the degree of cold work.

## Typical Chemistry (%)

	FWM 1058 average	ALTERNATE TRADE NAMES			
		Conichrome/Elgiloy		Phynox	
		min	max	min	max
Carbon	0.096	-	0.15	-	0.15
Manganese	1.68	1.5	2.5	1.0	2.0
Silicon	0.015	-	1.20	-	1.20
Phosphorus	0.006	-	0.015	-	0.015
Sulfur	0.001	-	0.015	-	0.015
Cobalt	40.34	39.0	41.0	39.0	42.0
Chromium	20.08	19.0	21.0	18.5	21.5
Nickel	15.28	14.0	16.0	15.0	18.0
Molybdenum	6.80	6.0	8.0	6.5	7.5
Beryllium	<0.001	-	0.1	-	0.001
Iron	balance	bal.	bal.	bal.	bal.

## Physical Properties

Density:	0.300 lbs/in <sup>3</sup>
Modulus of Elasticity:	29.0 x 10 <sup>6</sup> psi
Electrical Resistivity:	996 μohms-mm
Thermal Conductivity:	12.5 W/m K (0-100°C)

## Thermal Treatment

After cold working, the mechanical strength of this cobalt based super alloy can be increased by heat treating. In wire form, cold worked FWM 1058 will gain tensile strength at temperatures from 480-540°C when exposed for approximately 2-5 hours. Reducing or inert atmospheres are typically used for protection during thermal treatment. After annealing with a rapid quench, the alloy has a face-centered cubic structure.

## Magnetic Resonance Imaging (MRI)

Surgical implants constructed of FWM 1058 wire can be safely imaged using magnetic resonance without risk of migration and with minimal image degradation because of the nonmagnetic characteristics of the material.

## Biocompatibility

Although there is no universally accepted definition for biocompatibility of biomaterials, a medical device should be safe for its intended use. ASTM F1058 has been employed successfully in human implant applications in contact with soft tissue and bone for over a decade.

Long-term clinical experience of the use of this material has shown that an acceptable level of biological response can be expected if the alloy is used in appropriate applications.

## Surface Conditions

Cobalt based alloys develop a highly polished appearance as they are drawn to fine diameters. Surface roughness can be less than 5 microinches RMS when processed using single crystal natural diamond dies and measured with a profilometer. Diameters over .040" are finished with polycrystalline dies and therefore exhibit a rougher surface. Wire measuring over 0.100" will have an even rougher surface because it is drawn through carbide dies. However, the surface of the wire can be enhanced with additional finish treatments.

# FWM 1058

## Applications

Because of its excellent corrosion resistance, mechanical strength and fatigue resistance combined with high elastic modulus, FWM 1058 wire and rod is an attractive candidate for surgical implants. It is one of the preferred materials for the fabrication of various stents, pacemaker lead conductors, surgical clips, vena cava filters, orthopaedic cables, and orthodontic appliances. The alloy is also commonly used in the watchmaking industry as a precision spring material.

## Mechanical Properties

% Cold Work	U.T.S. (psi)	% Elongation (10" gage length)
0%	150,000	55%
20%	205,000	9%
37%	245,000	5%
50%	275,000	3.9%
60%	295,000	3.8%
68%	312,000	3.8%
75%	325,000	3.9%

Values are typical and may not represent all diameters. Test method will affect results.

# MP35N<sup>®</sup>

## Melt Practice

This superalloy is typically double melted to remove impurities.

### Typical Chemistry

	FWM Avg. Wt. %	ASTM F562
Carbon	.010	0.025
Manganese	.060	0.15
Silicon	.030	0.15
Phosphorus	.002	0.015
Sulfur	.001	0.010
Chromium	20.580	19.0-21.0
Nickel	34.820	33.0-37.0
Molybdenum	9.510	9.0-10.5
Iron	.520	1.0
Titanium	.430	1.0
Boron	.010	0.015
Cobalt	balance	balance

FWM chemistry is for reference only, and is not to be used for specification purposes.

### Physical Properties

Density	.304 lbs/in <sup>3</sup>
Modulus of Elasticity	33.76-34.05 x 10 <sup>6</sup> psi
Electrical Resistivity	1033 μohms-mm
Thermal Conductivity	11.2 W/m K (100°C)

## Thermal Treatment

A reducing atmosphere is preferred for thermal treatment but inert gas can be used. MP35N will fully anneal at 1010-1177°C in just a few minutes. For optimum mechanical properties, cold worked MP35N should be aged at 583-593°C for four hours.

## Applications

MP35N is an excellent combination of strength and corrosion resistance. Typically used in the cold-worked condition, tensile strengths are comparable to 304. End uses in the medical field are: pacing leads, stylets, catheters and orthopaedic cables.

### Mechanical Properties

% Cold Work	U.T.S. (psi)	% Elongation (10" gage length)
0%	152,000	50%
20%	201,000	7%
37%	253,000	3%
50%	285,000	2.5%
60%	303,000	3.2%
68%	319,000	3.0%
75%	329,000	3.1%
80%	332,000	3.3%
84%	339,000	3.2%
90%	345,000	3.4%
93%	346,000	2.2%
95%	362,000	2.8%

Values are typical and may not represent all diameters. Test method will affect results.

## Surface Conditions

Cobalt based alloys develop a highly polished appearance as they are drawn to fine diameters. Surface roughness can be less than 5 microinches RMS when processed using dies and measured with a profilometer. Diameters over .040" are finished with polycrystalline dies and exhibit a rougher surface than natural diamond dies. Diameters over 0.100" have an even rougher surface because they are drawn with carbide dies. Additional finish treatments can enhance the surface of the wire.

# 35N LT<sup>®</sup>

## Melt Practice

This superalloy is typically double melted to remove impurities. However, this melt practice is an enhancement of the standard melt practice for ASTM F562 material yielding much lower inclusion counts. This results in improved fatigue life of as-drawn wire by as much as 800%.

## Typical Chemistry

	FWM Avg. Wt. %	ASTM F562
Carbon	0.010	0.025
Manganese	0.06	0.15
Silicon	0.03	0.15
Phosphorus	0.002	0.015
Sulfur	0.001	0.010
Chromium	20.58	19.0-21.0
Nickel	34.82	33.0-37.0
Molybdenum	9.51	9.0-10.5
Iron	0.52	1.0
Titanium	<=.01	1.0
Boron	0.010	0.015
Cobalt	balance	balance

FWM chemistry is for reference only, and is not to be used for specification purposes.

## Physical Properties

	English	Metric
Density	.304 lbs/in <sup>3</sup>	8.41 g/cc
Modulus Of Elasticity	33.8e6 psi	233 Gpa
Electrical Resistivity	40.7 μohm-in	1033 μohm-mm
Thermal Conductivity	77.7 Btu-in/hr-ft <sup>2</sup> -°F	11.2 W/m K
Thermal Coefficient of Expansion	7.11 μin/in-°F	12.8 μm/m-°C

## Thermal Treatment

A reducing atmosphere is preferred for thermal treatment but inert gas can be used. 35N LT will fully anneal at 1010-1177°C in just a few minutes. For optimum mechanical properties, cold worked 35N LT should be aged at 583-593°C for four hours.

## Applications

35N LT is an excellent combination of strength and corrosion resistance. Typically used in the cold-worked condition, tensile strengths are comparable to 304. End uses in the medical field are: pacing leads, stylets, catheters and orthopaedic cables.

## Mechanical Properties

% Cold Work	Y.S. ksi (MPa)	U.T.S. ksi (MPa)	% Elongation (10" gage length)
0%	130 (896)	190 (1310)	40.0%
20%	190 (1310)	240 (1655)	8.0%
37%	240 (1655)	280 (1931)	3.8%
50%	270 (1862)	300 (2268)	3.8%
60%	290 (1999)	320 (2206)	3.5%
68%	300 (2068)	330 (2275)	3.5%
75%	305 (2103)	340 (2344)	3.3%
80%	315 (2172)	350 (2413)	3.0%
84%	325 (2241)	360 (2482)	3.0%
90%	333 (2296)	370 (2551)	3.0%
93%	338 (2330)	375 (2586)	2.5%
95%	340 (2344)	380 (2620)	2.5%

Values are typical for diameters smaller than .010 in (.254mm).

## Rotary Beam Fatigue

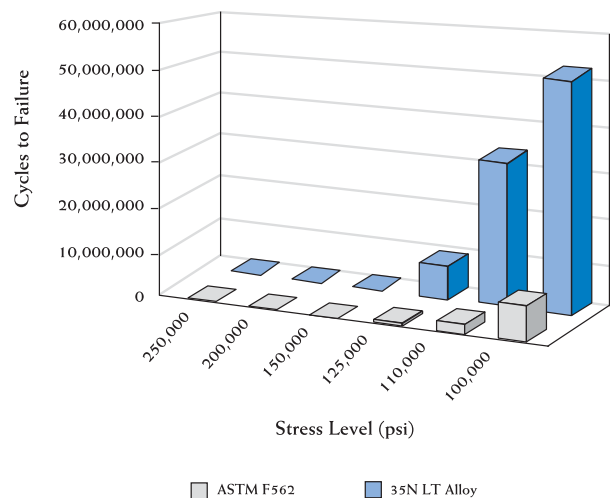

35N LT is a registered trademark of Fort Wayne Metals Research Products Corp. ©2011

# L-605

## Melt Practice

L-605 is a cobalt-chromium-tungsten-nickel alloy and is typically double melted to remove impurities.

### Typical Chemistry

	FWM Avg. Wt. %	ASTM F90
Carbon	0.10	0.05-0.15
Manganese	1.5	1.00-2.00
Silicon	0.40**	0.40**
Phosphorus	0.040**	0.040**
Sulfur	0.030**	0.030**
Chromium	20.0	19.00-21.00
Nickel	10.0	9.00-11.00
Tungsten	15.0	14.00-16.00
Iron	3.0**	3.00**
Cobalt	51.0*	balance

\* As balance \*\* Maximum

FWM chemistry is for reference only, and is not to be used for specification purposes.

### Physical Properties

Density	0.333 lbs/in <sup>3</sup>
Modulus of Elasticity	32.6 x 10 <sup>6</sup> psi (room temp.)
Thermal Conductivity	9.4 W/m K (room temp.)

## Description

L-605 alloy is a nonmagnetic, cobalt-chromium-tungsten-nickel alloy. The high strength properties of this alloy may be obtained through work hardening. It remains nonmagnetic in the work-hardened condition.

## Thermal Treatment

The alloy is normally solution-treated in the range of 2150°F-2250°F (1175°C-1230°C), then rapid air cooled or water-quenched to attain optimum properties. Annealing at lower temperatures may cause some precipitation of carbide, which is undesirable for the achievement of many properties.

## Applications

L-605 has good oxidation and corrosion resistance as well as excellent high strength properties at elevated temperatures. The alloy is typically used in the cold-worked condition. A modest increase in hardness and strength can be achieved through aging of the cold worked material. End uses in

the medical field are: stents, bone drill bits, cerclage cables, guide rods, orthopaedic cables, heart valves and various other orthopaedic applications.

## Surface Conditions

Cobalt based alloys develop a highly polished appearance as they are drawn to fine diameters. Surface roughness can be reduced when processed using single crystal natural diamond dies. Diameters over .040" will not have as smooth a finish because of poly-crystalline dies. Diameters over .070" will be carbide drawn and supplied with a more textured surface. Additional finish treatments can enhance the surface of the wire. Material above .070" is often centerless ground and polished when supplied as straightened and cut bar. This process yields a lustrous surface finish and maintains a tight tolerance for precision machining applications.

### Mechanical Properties - Wire

% Cold Work	U.T.S. (psi)	(10" gage length)
0%	165,000	50%
20%	240,000	9%
37%	290,000	6%
50%	325,000	3.6%

### Mechanical Properties - Straightened and Cut Bar

	U.T.S. (psi)	Y.S. (psi)	% Elongation (2" gage length)
Annealed	150,000	75,000	40%
Cold worked	200,000	150,000	25%

Values are nominal and may not represent all diameters. Test method will affect results.

## Machinability

L-605 is machinable using conventional techniques; however cobalt grades of high-speed steel or carbide tools combined with right machine setups are recommended. L-605 is more difficult to machine than the austenitic stainless steels (e.g. Types 302, 304, 321, and 347 stainless). Generally, lower feed speeds and depths of cut are suggested. A very high work-hardening rate, generation of heat during cutting and a high shear strength complicate machining.

### L-605 Specifications

ASTM F90	ASTM F1091	UNSR30605
AMS5796	AMS 5759	ISO 5832-5

# FWM™ 1537 (ASTM F1537, ISO 5832-12)

FWM 1537 is a low carbon wrought Cobalt-Chromium-Molybdenum alloy ideal for applications in medical and aerospace industries. It has high strength, ductility, wear resistance, corrosion resistance and biocompatibility.

## Typical Chemistry

	FWM™ 1537 (wt%)	ASTM F 1537 Alloy 1 (wt%)
Carbon	0.01-0.04	<0.14
Chromium	27.5	26-30
Molybdenum	5.5	5-7
Nickel	0.05-0.4	<1.0
Iron	<0.5	<0.75
Silicon	<0.6	<1.0
Manganese	<1.0	<1.0
Nitrogen	<0.2	<0.25
Cobalt	balance	balance

FWM chemistry in this table is for reference only and should not be used for specification purposes.

## Physical Properties at Room Temperature

Density:	0.3 lbs/in <sup>3</sup>
Modulus of Elasticity:	35 Mpsi
Thermal Conductivity:	12.6 W/m K
Coefficient of Thermal Expansion:	13.2×10 <sup>-6</sup> in/in/°C (20 – 100°C)

## Thermal Treatment

This alloy is normally solution treated at temperatures around 2000°F for one hour, followed by a rapid quench with water or compressed air to ensure optimum properties. Annealing or aging at lower temperatures may cause the precipitation of carbides or phase transformation, which can significantly reduce ductility.

## Mechanical Properties

FWM 1537 can be provided in coil form (typical size range from 0.004" to 0.45") or as straight bars (typical size range from 0.06" to 0.4"). Coiled material can be annealed or cold worked, with the mechanical properties depending on the amount of cold work. The figure below illustrates the influence of cold work on mechanical properties.

## Effect of cold work on mechanical properties:

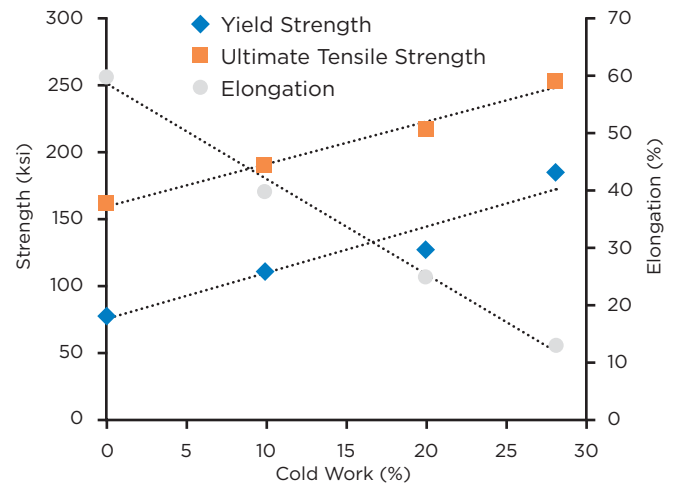

## FWM 1537 bars can be provided in three conditions:

annealed, hard and spring. The typical mechanical properties of each condition are listed in the table below.

## Typical Mechanical Properties of FWM 1537 bar products:

Condition	U.T.S. (ksi)	Y.S. (ksi)	HRC	Elongation (%)
Annealed	150-170	80-110	30-35	>25
Hard*	170-195	110-130	~40	>30
Spring	>230	130-150	50-52	>20

\* This material condition is similar to the ASTM condition "warm worked." The properties are similar, but the material is cold worked only. No thermal processing is used to achieve these properties.

## Surface condition

FWM 1537 develops a highly polished appearance when drawn to fine diameters. Surface roughness can be decreased by using single crystal natural diamond dies. Large diameter wires (>0.05") will be drawn by carbide dies and thus have a more textured surface. Bar products are normally centerless ground and polished, which provides a lustrous surface finish and maintains a tight tolerance for precision machining applications.

# FWM 1537

## Applications

FWM 1537 is currently used in the medical industry to manufacture implants such as hip and knee replacements, spinal rods and screws. Due to its unique properties, FWM 1537 has great potential in any industrial application that requires high strength, wear and corrosion resistance, for instance in aerospace bushings and bearings.

		Ultimate Tensile Strength (ksi)	0.2 % Yield Strength (ksi)	Elongation (%)	Reduction of Area (%)	Typical HRC Hardness
<b>Annealed</b>	ASTM	130 min	75 min	20 min	20 min	25
	FWM Typical Properties	150-170	80-110	>25	>20	30-35
<b>Hard</b>	ASTM Warm Worked	145 min	101 min	12 min	12 min	28
	FWM Typical Properties	170-195	110-130	>30	>20	40
<b>Spring</b>	FWM Typical Properties	>230	130-150	>20	>20	50-52

# Unalloyed Commercially Pure Titanium

Unalloyed Commercially Pure (CP) Titanium is represented by four distinct grades, specifically 1, 2, 3 and 4. CP Titanium is ordered in relation to the corrosion resistance, formability (ductility) and strength requirements of a specific application. CP Titanium ranges from grade 1, which has the highest corrosion resistance, formability and lowest strength, to grade 4, which offers the highest strength and moderate formability. CP Titanium end users utilize excellent corrosion resistance, formability and weldable characteristics for many critical applications.

Chemistry	ASTM F67			
	Grade 1	Grade 2	Grade 3	Grade 4
Nitrogen, max.	0.03	0.03	0.05	0.05
Carbon, max.	0.08	0.08	0.08	0.08
Hydrogen, max.	0.015	0.015	0.015	0.015
Iron, max.	0.20	0.30	0.30	0.50
Oxygen, max.	0.18	0.25	0.35	0.40
Titanium	balance	balance	balance	balance

FWM chemistry is for reference only, and is not to be used for specification purposes.

Physical Properties	
Density	0.163 lbs/in <sup>3</sup>
Modulus of Elasticity	14.9 x 10 <sup>6</sup> psi
Electrical Resistivity	0.42-0.52 μohms-m
Thermal Conductivity	16-22 W/m K

## Surface Conditions

CP Titanium has a tendency to stick, fret or cold weld with drawing dies during processing. Common industry practice to avoid this condition employs heavy etching or pickling at finish size resulting in a coarse or very textured surface. Fort Wayne Metals has developed processing techniques with enhanced surface treatments that require minimal etching at finish size to remove most residual oxide, yielding a cleaner and smoother surface finish. Material can be purchased with this improved surface finish or with a retained water soluble lubricant for applications where lubricity of the wire is required (e.g. weaving applications).

## Diameter Tolerances

Enhanced surface treatments and processing techniques allow Fort Wayne Metals to offer tighter and more controlled tolerances. The chart in the right column details standard diameter tolerances for CP Titanium in wire and coil forms. Most diameters can be produced to tighter tolerances.

## Applications

Fort Wayne Metals manufactures CP Titanium in straightened and cut bar, coil, strands and cables, flat wire and wire form to support a variety of critical medical and industrial based applications.

### End uses include:

- |                          |                        |
|--------------------------|------------------------|
| Orthopaedic applications | Sutures                |
| Needles                  | Ligature clips         |
| Pacing leads             | Orthodontic appliances |
| Woven wire mesh          | Eye glass frames       |

### Mechanical Properties ASTM F67

Grade	U.T.S. min., ksi (MPa)	Y.S. min., (2% offset) ksi (MPa)	% Elongation (2" gage length) minimum
1	35 (240)	25 (170)	24
2	50 (345)	40 (275)	20
3	65 (450)	55 (380)	18
4	80 (550)	70 (483)	15

Values are typical and may not represent all diameters. Test method will affect results.

### Approximate FWM Tensile Properties

Grade	Condition	U.T.S. ksi (MPa)
1	Cold Worked	85-115 (586-793)
1	Annealed	45-75 (310-517)
2	Cold Worked	110-140 (758-965)
2	Annealed	65-90 (448-621)
4	Cold Worked	135-165 (931-1138)
4	Annealed	95-120 (655-827)

Values are typical and may not represent all diameters. Test method will affect results. CP Titanium in centerless ground bar, coil, and wire can be offered in annealed or cold worked conditions.

# Unalloyed Commercially Pure Titanium

## Standard Tolerances

Diameter in inches (mm)		Standard Tolerance +/-
Including	Under	
0.0010 (0.0254)	0.0048 (0.1219)	0.0001 (0.0025)
0.0048 (0.1219)	0.0080 (0.2032)	0.0002 (0.0051)
0.0080 (0.2032)	0.0120 (0.3048)	0.0003 (0.0076)
0.0120 (0.3048)	0.0240 (0.6096)	0.0004 (0.0102)
0.0240 (0.6096)	0.0330 (0.8382)	0.0005 (0.0127)
0.0330 (0.8382)	0.0440 (1.1176)	0.0008 (0.0203)
0.0440 (1.1176)	0.2510 (6.3754)	0.0010 (0.0254)

## Product Capability

### Wire

Fort Wayne Metals utilizes state-of-the-art equipment and processing techniques to provide precision drawn CP Titanium. Wire is typically provided on standard FWM spools (see packaging and spooling data sheet). Custom packaging or spools will be considered based on our equipment capabilities.

#### Diameter Range

0.001" (0.0254mm) to 0.062" (1.5748mm)

### Coil

Fort Wayne Metals provides precision loose wound coils for many critical applications, coil weights can reach a maximum of 100 pounds, nominal 50 pound weight depending on diameter.

#### Diameter Range

0.040" (1.016mm) to 0.500" (12.7mm)

#### Packaging (coil I.D.)

0.040" (1.016mm) to 0.125" (3.175mm) = 20" (508mm) nominal

0.100" (2.54mm) to 0.500" (12.7mm) = 28" (711mm) nominal

## Centerless and Precision Ground Bar

Fort Wayne Metals provides straightened and cut bar product in centerless and precision ground conditions. Customers can order discrete lengths, however material is typically manufactured in 10' (3048mm) to 12' (3657mm) random lengths. Available diameters range from 0.0787" (2.0mm) to 0.500" (12.7mm). Standard Tolerances are given below. Most diameters can be produced to tighter tolerances if required.

#### Diameter Range

	Standard Tolerance	Surface Roughness (RMS)
Centerless Ground Bar	+/- 0.001" (0.0254mm)	24 or better
Precision Ground Bar	+/- 0.0005" (0.0127mm)	16 or better

## Other Titanium & Titanium Alloys Available

CP Ti Gr.1	Ti 6Al-4V ELI
CP Ti Gr.2	Ti 6Al-7Nb
CP Ti Gr.3	Ti 3Al-2.5V
CP Ti Gr.4	Ti 3Al-8V-6Cr-4Mo-4Zr (Ti Beta C)

Other titanium and titanium alloys will be considered upon request.

# Ti 6Al-4V ELI

One of the most commonly used titanium alloys is an alpha-beta alloy containing 6% Al and 4% V. This alloy, usually referred to as Ti 6Al-4V, exhibits an excellent combination of corrosion resistance, strength and toughness. Typical uses include medical devices or implants, aerospace applications and pressure vessels. In the case of medical applications, stringent user specifications require controlled microstructures and freedom from melt imperfections. The interstitial elements of iron and oxygen are carefully controlled to improve ductility and fracture toughness. Controlled interstitial element levels are designated ELI (extra low interstitials), hence the designation Ti 6Al-4V ELI.

## Chemistry

	FWM Avg. Wt. %	ASTM F136
Nitrogen, max.	0.011	0.05
Carbon, max.	0.015	0.08
Hydrogen, max.	0.0058	0.012A
Iron, max.	0.12	0.25
Oxygen, max.	0.11	0.13
Aluminum	6.06	5.5-6.50
Vanadium	3.97	3.5-4.5
Titanium	balance	balance

FWM chemistry is for reference only, and is not to be used for specification purposes. A Material .032" (0.813mm) and under may have hydrogen content up to .0150%.

## Surface Conditions

Ti 6Al-4V ELI has a tendency to stick, fret or cold weld with drawing dies during processing. Common industry practice to avoid this condition employs heavy etching or pickling at finish size resulting in a coarse or very textured surface. Fort Wayne Metals has developed processing techniques with enhanced surface treatments which require minimal etching at finish size to remove residual oxide, yielding a cleaner and smoother surface finish.

## Diameter Tolerances

Enhanced surface treatments and processing techniques allow Fort Wayne Metals to offer tighter and more controlled tolerances. The chart in the column to the right details standard diameter tolerances for Ti 6Al-4V ELI in wire and coil forms. Most diameters can be produced to tighter tolerances.

## Applications

Fort Wayne Metals manufactures Ti 6Al-4V ELI in straightened and cut bar, coil, strands and cables, flat wire and wire form to support a variety of critical medical and industrial based applications. End uses include:

Orthopaedic pins and screws	Springs
Orthopaedic cables	Surgical staples
Orthodontic appliances	Ligature clips

## Mechanical Properties per ASTM F136

Size in. (mm)	U.T.S. min., ksi (MPa)	Y.S. min., (2% offset) ksi (MPa)	% Elongation minimum
Under 0.187 (4.75)	125 (860)	115 (795)	10% (2" gage length)
0.187 to 0.250 (4.75 to 6.35)	125 (860)	115 (795)	10% (4D)

## Approximate FWM Mechanical Properties

Condition	U.T.S. ksi (MPa)	% Elongation (2" gage length)
Cold Worked	190-210 (1310-1448)	3%-7%
Cold Worked/ Stress Relieved	170-190 (1172-1310)	5%-10%
Annealed	145-170 (1000-1172)	10% min.

Values are typical and may not represent all diameters. Test method will affect results. Ti 6Al-4V ELI centerless ground bar, coil and wire is available in annealed or cold worked condition.

## Physical Properties

Density	0.160 lbs/in <sup>3</sup>
Modulus of Elasticity	16.5 x 10 <sup>6</sup> psi
Electrical Resistivity	1.71 μohms-m
Thermal Conductivity	6.6-6.8 W/m K

## Standard Tolerances

Diameter in inches (mm)		
Including	Under	Standard Tolerance +/-
0.0010 (0.0254)	0.0048 (0.1219)	0.0001 (0.0025)
0.0048 (0.1219)	0.0080 (0.2032)	0.0002 (0.0051)
0.0080 (0.2032)	0.0120 (0.3048)	0.0003 (0.0076)
0.0120 (0.3048)	0.0240 (0.6096)	0.0004 (0.0102)
0.0240 (0.6096)	0.0330 (0.8382)	0.0005 (0.0127)
0.0330 (0.8382)	0.0440 (1.1176)	0.0008 (0.0203)
0.0440 (1.1176)	0.2510 (6.3754)	0.0010 (0.0254)

# Ti 6Al-4V ELI

## Product Capability

### Wire

Fort Wayne Metals utilizes state-of-the-art equipment and processing techniques to provide precision drawn Ti 6Al-4V ELI. Wire is typically provided on standard FWM spools (see packaging and spooling data sheet). Custom packaging or spools will be considered based on our equipment capabilities.

#### Diameter Range

0.001" (0.0254mm) to 0.062" (1.5748mm)

### Coil

Fort Wayne Metals provides precision loose wound coils for many critical applications. Coil weights are a nominal 50 pounds and can reach a maximum of 100 pounds depending on diameter.

#### Diameter Range

0.040" (1.016mm) to .47244" (12mm)

#### Packaging (coil I.D.)

0.040" (1.016mm) to 0.125" (3.175mm) = 20"  
(508mm) nominal

0.100" (2.54mm) to .47244" (12mm) = 28"  
(711mm) nominal

### Centerless and Precision Ground Bar

Fort Wayne Metals provides straightened and cut bar product in centerless and precision ground conditions. Customers can order discrete lengths, however material is typically manufactured in 10' (3048mm) to 12' (3657mm) random lengths. Available diameters range from 0.0787" (2.0mm) to 0.47244" (12mm). Standard Tolerances are given below. Most diameters can be produced to tighter tolerances if required.

#### Diameter Range

	Standard Tolerance	Surface Roughness (RMS)
Centerless Ground Bar	+/- 0.001" (0.0254mm)	24 or better
Precision Ground Bar	+/- 0.0005" (0.0127mm)	16 or better

### Other Titanium & Titanium Alloys Available

CP Ti Gr.1	Ti 6Al-4V ELI
CP Ti Gr.2	Ti 6Al-7Nb
CP Ti Gr.3	Ti 3Al-2.5V
CP Ti Gr.4	Ti 3Al-8V-6Cr-4Mo-4Zr (Ti Beta C)

Other titanium and titanium alloys will be considered upon request.

# Medical Grade Nitinol Wire for Super-Elastic Applications

Fort Wayne Metals manufactures three medical grades (NiTi#1, NiTi#2 and NiTi#4) of Nickel-Titanium or Nitinol wire products available in either the cold worked (CW) condition ready for heat treatment or as straightened super-elastic (SE) wire.

Each medical grade of Nitinol material is comprised of near equal atomic weight percentage of nickel and titanium. Our most common medical grade, NiTi#1, exceeds chemistry requirements set forth by ASTM F2063 for use in surgical implants. At Fort Wayne Metals, all incoming Nitinol raw materials are inspected to ensure they meet proprietary internal specifications for chemistry, ingot transformation temperature, material homogeneity, and microstructure. Optimized to promote an exceptionally smooth and uniform surface finish quality, all wire products utilize a proprietary single and multi crystalline diamond drawing die technology. Medical grade Nitinol wire may be purchased in the cold worked (CW) or the super-elastic condition (SE) and after the correct super-elastic heat treatment will accommodate strain up to 8% without permanent kinking at body temperature. The transformation temperatures and mechanical properties for each of our three standard grades of Nitinol are presented in the table at the bottom of the page.

## Nitinol Wire Applications

Our Nitinol wire is used for many different medical and industrial applications. The table below gives some typical engineering applications for each of our standard Nitinol medical grades:

Grade	Application
NiTi#1	guidewires, stents, stylets, forming mandrels, stone retrieval baskets, orthodontic files, etc.
NiTi#2	Ideal for applications that require high loading and unloading plateau stresses at room temperature, cell phone antennae, eyeglass frames.
NiTi#4	Provides the best cycling performances at 37°C body temperature.

## Nitinol #1 - Typical Chemistry For Surgical Implants

	ASTM F2063	FWM NiTi#1 (Average)
Nickel	54.5-57.0 wt%	56.0 wt%
Carbon	500 ppm	330 ppm
Oxygen	500 ppm	280 ppm
Hydrogen	50 ppm	25 ppm
Titanium	balance	balance

## Certification Data Package

UTS-Elongation  
 Upper and lower plateau stress (SE only)  
 Fully annealed ingot transformation measured by DSC  
 Wire transformation measured by Bend & Free Recovery (SE only)  
 Two test temperatures available: 22°C +/- 2°C or 37°C +/- 2°C  
 Permanent set after straining to 6% or 8% strain (SE only)  
 Multiple gauge length and crosshead speeds  
 Chemical analysis

## Nitinol Product Forms

Round Wire: 0.0005" to 0.250"  
 Flat Wire: Aspect Ratio: W/T ~ 12  
 Minimum Thickness: 0.0003"  
 Maximum Width: 0.100"  
 Turckhead: Square, Rectangular  
 Custom Shapes: A wide variety of shaped cross-sectional wire  
 Stranded Cables: 1x3, 1x7, 1x19, Materials Blends, etc.  
 DFT®: Composites manufactured with a Nitinol core or clad jacket

If your Nitinol product need falls outside of the standard medical grade material or the available product forms, please contact one of our Nitinol application sales engineers.

# Medical Grade Nitinol Wire for Super-Elastic Applications

## Mechanical Properties

Product	CW = (Cold Worked)		SE = (Super-Elastic Straight)				
	Ingot A <sub>s</sub> (°C)	UTS (psi)	UTS (psi)	Elongation (%)	Loading Plateau (ksi)	Unloading Plateau (ksi)	Active A <sub>f</sub> (°C)
NiTi#1(N1)	-35 to -10	200,000 min	180,000 min	> 10%	> 70,000	> 20,000	+10 to +18
NiTi#2(N2)	-45 to -15	250,000 min	210,000 min	> 10%	> 80,000	> 35,000	0 to +18
NiTi#4(N4)	-10 to +10	200,000 min	180,000 min	> 10%	> 65,000	> 15,000	+14 to +22
Notes =>	Elongation at break > 4%		Permanent Set < 0.5% after strained to 8%		Elongation at Break > 10%		
	All Mechanical Testing Conducted at 22°C +/- 2°C						

## Surface Finishes Available

<b>Light Oxide (LO)</b> Gold to Brown color - diamond drawn surface
<b>Dark Oxide (DK)</b> Blue to Black color - diamond drawn surface
<b>Black Oxide (BLK)</b> Shiny Black color - diamond drawn surface
<b>Etch (E)</b> Chemical removal of oxide layer - will maintain smooth surface
<b>Pickled (P)</b> Chemical removal of oxide layer along with a slight amount of base metal - surface will have rough texture
<b>Etched and Mechanically Polished (EMP)</b> Chemical removal of oxide layer followed by mechanical polish - surface will have Stainless Steel appearance although at > 40x magnification micro scratches are present

## Additional Services Available

<b>Wire Cleaning:</b> hot alkaline or alcohol wipe
Continuous eddy current surface analysis
Rotary beam fatigue testing
Metallurgical lab testing
X-ray Diffraction (XRD), Transmission Electron Microscopy (TEM), Auger Electron Spectroscopy (AES), Scanning Electron Microscope (SEM), Electron Dispersive Spectroscopy (EDS)

## How To Specify and Order Medical Grade Nitinol Round Wire

Wire Diameter	Nitinol Grade	Condition	Surface Finish
Specify Std. Wire Diameter < 0.040" (4 decimal places) (Std Wire Tolerance Per ASTM A-555)	NiTi#1 NiTi#2 NiTi#4	Cold Worked Super-Elastic	LO - Light Oxide DK - Dark Oxide BLK - Shiny Black E - Etched Bright P - Pickled EMP - Etched and Mechanically Polished

# Nitinol #1 Wire

## 1.0 Scope

1.1 This specification covers all necessary information for the purchasing of Nitinol #1 round wires having a diameter  $\geq 0.001$ " (0.025mm) and  $\leq 0.040$ " (1.016mm).

## 2.0 Product Definition

NiTi#1-CW Nitinol #1 Cold Worked

NiTi#1-SE Nitinol #1 Super-Elastic Straight Annealed

Add desired suffix to select oxide finish as described in Paragraph 8.1.

## 3.0 Applicable Documents

ASTM A555	Standard Specification for General Requirements for Stainless Steel Wire and Wire Rods
ASTM F2005	Standard Terminology for Nickel-Titanium Shape Memory Alloy
ASTM F2004	Standard Test Method for Transformation Temperature of Nickel-Titanium Alloys by Thermal Analysis
ASTM F2063	Standard Specification for Wrought Nickel-Titanium Shape Memory Alloys for Medical Devices and Surgical Implants
ASTM F2516	Standard Test Method for Tension Testing of Nickel-Titanium Super-Elastic Materials

## 4.0 Chemical Composition

4.1 The chemical composition of the material shall be equal to or better than those defined by ASTM F2063. FWM meets or exceeds the following chemical composition requirements:

Element	Weight %
Nickel . . . . .	54.5 to 57.0 (Reference)
Carbon . . . . .	< 0.050 (500 ppm maximum)
Cobalt . . . . .	< 0.050 (500 ppm maximum)
Copper . . . . .	< 0.010 (100 ppm maximum)
Chromium . . . . .	< 0.010 (100 ppm maximum)
Hydrogen . . . . .	< 0.005 (50 ppm maximum)
Iron . . . . .	< 0.050 (500 ppm maximum)
Niobium . . . . .	< 0.025 (250 ppm maximum)
Nitrogen plus Oxygen . . . . .	< 0.050 (500 ppm maximum)
Any Single Trace Element . . . . .	< 0.1
Total Trace Elements . . . . .	< 0.25
Titanium . . . . .	balance

# Nitinol #1 Wire

## 5.0 Transformation Properties

- 5.1 The fully annealed ingot austenite start ( $A_s$ ) temperature shall be  $-35^{\circ}\text{C}$  to  $-10^{\circ}\text{C}$  when measured by DSC in accordance with ASTM F2004.
- 5.2 Materials ordered in the Super-Elastic Straight Annealed (NiTi#1-SE) condition will have a finish  $A_f$  temperature between  $+10^{\circ}\text{C}$  to  $+18^{\circ}\text{C}$  when tested per FWM procedures.

## 6.0 Applicable Wire Sizes and Standard Tolerances

(in accordance with ASTM A 555)

Specified Size (inches)	Standard Tolerance (inches)
$\leq 0.040$ to $0.033$	$\pm 0.0008$
$< 0.033$ to $0.024$	$\pm 0.0005$
$< 0.024$ to $0.012$	$\pm 0.0004$
$< 0.012$ to $0.008$	$\pm 0.0003$
$< 0.008$ to $0.0048$	$\pm 0.0002$
$< 0.0048$ to $0.001$	$\pm 0.0001$

Notes: 1) Tighter tolerance available upon request  
2) Out of round tolerance shall be one-half the total size tolerance

## 7.0 Mechanical Properties

7.1 All Mechanical Testing Conducted at  $22^{\circ}\text{C} \pm 2^{\circ}\text{C}$

7.2 Cold Worked Wire (NiTi#1-CW)

The cold worked wire shall conform to the following mechanical properties:

Cold Work	45% +/- 5%
Ultimate Tensile Strength	200,000 psi minimum
Tensile Elongation at Failure	4% minimum (as measured by the above referenced document)

7.3 Super-Elastic Wire (NiTi#1-SE)

Ultimate Tensile Strength	180,000 psi
Elongation at Break	> 10%
Loading Plateau	> 70,000 psi at 4% Strain
Unloading Plateau	> 20,000 psi at 4% Strain (after an initial strain to 8%)
Permanent Set after 8% Strain and Unloading	< 0.5%

## 8.0 Surface Finish and Appearance

### 8.1 Surface Finishes:

Order Code Suffix	Description	Appearance
-EMP	Etched & Mechanically Polished	Bright
-E	Etched Bright	Bright
-LO	Light Oxide	Gold to Brown
-P	Pickled	Dull Matt
-DK	Dark Oxide	Blue to Black
-BLK	Black Oxide	Shiny Black Color

8.2 Wire must be clean of contaminants, smooth, free from bumps, kinks, waves, scrapes, splits, burrs and other surface defects.

## 9.0 Quality Assurance Provisions

9.1 Each lot of material is to be manufactured from a single source of raw material under known process conditions.

9.2 Supplier will be notified of any revision changes to this specification.

## 10.0 Certification and Spool Labeling

10.1 A certificate of compliance to this product number shall accompany each shipment.

10.2 Each spool shall be labeled with the:  
Product Type  
FWM Manufacturing or Production #  
Heat #  
FWM Part #  
Size  
Feet or Pounds (as applicable)

## 11.0 Packaging

11.1 The wire must be wound evenly on the spools, with no breaks or tangles.  
The maximum weight per spool shall be as follows unless specified otherwise on the purchase order.

Wire Size	Maximum Weight	Spool Type
0.001" to 0.003"	0.5 pounds	2.5"x3", DIN80, DIN100, DIN125, Steeger, NE #2, Wardwell Bobbins
> 0.003" to < 0.012"	5 pounds	2.5"x3", DIN100, DIN125, Weldwire Reel
> 0.012" to 0.018"	10 pounds	Weldwire Reel
> 0.018" to 0.035"	20 pounds	Weldwire Reel

# Nitinol #2 Wire

## 1.0 Scope

1.1 This specification covers all necessary information for the purchasing of Chrome Doped Nitinol #2 round wires having a diameter  $\geq 0.001''$  (0.025mm) and  $\leq 0.040''$  (1.016mm).

## 2.0 Product Definition

NiTi#2-CW Nitinol #2 Cold Worked

NiTi#2-SE Nitinol #2 Super-Elastic Straight

Add desired suffix to select oxide finish as described in Paragraph 8.1.

## 3.0 Applicable Documents

ASTM A555 Standard Specification for General Requirements for Stainless Steel Wire and Wire Rods

ASTM F2005 Standard Terminology for Nickel-Titanium Shape Memory Alloy

ASTM F2004 Standard Test Method for Transformation Temperature of Nickel-Titanium Alloys by Thermal Analysis

ASTM F2516 Standard Test Method for Tension Testing of Nickel-Titanium Super-Elastic Materials

## 4.0 Chemical Composition

4.1 The chemical composition of the material shall be equal to or better than those below:

Element	Weight %
Nickel . . . . .	55.8 (reference)
Chromium . . . . .	0.20 to 0.30
Carbon . . . . .	< 0.05 (500 ppm maximum)
Oxygen . . . . .	< 0.05 (500 ppm maximum)
Iron . . . . .	< 0.03 (300 ppm maximum)
Copper . . . . .	< 0.01 (100 ppm maximum)
Cobalt . . . . .	< 0.05 (500 ppm maximum)
Any Single Trace Element . . .	< 0.1 (except Chromium)
Total Trace Elements . . . . .	< 0.4 (except Chromium)
Titanium . . . . .	balance

## 5.0 Transformation Properties

5.1 The fully annealed ingot austenite start ( $A_s$ ) temperature shall be  $-45^{\circ}\text{C}$  to  $-15^{\circ}\text{C}$  when measured by DSC in accordance with ASTM F2004.

5.2 Materials ordered in the Super-Elastic Straight Annealed (NiTi#2-SE) condition will have a finish  $A_f$  temperature between  $+0^{\circ}\text{C}$  and  $+18^{\circ}\text{C}$  when tested per FWM procedures.

## 6.0 Applicable Wire Sizes and Standard Tolerances

(in accordance with ASTM A 555)

Specified Size (inches)	Standard Tolerance (inches)
≤ 0.035 to 0.024	± 0.0005
< 0.024 to 0.012	± 0.0004
< 0.012 to 0.008	± 0.0003
< 0.008 to 0.0048	± 0.0002
< 0.0048 to 0.001	± 0.0001

Notes: 1) Tighter tolerance available upon request  
2) Out of round tolerance shall be one-half the total size tolerance

## 7.0 Mechanical Properties

7.1 All Mechanical Testing Conducted at 22°C +/- 2°C

7.2 Cold Worked Wire (NiTi#2-CW)

The cold worked wire shall conform to the following mechanical properties:

Cold Work	45% +/- 5%
Ultimate Tensile Strength	250,000 psi minimum
Tensile Elongation at Failure	4% minimum (as measured by the above referenced document)

## 7.3 Super-Elastic Wire (NiTi#2-SE)

Ultimate Tensile Strength	> 210,000 psi
Elongation at Break	> 10%
Loading Plateau	> 80,000 psi at 4% Strain
Unloading Plateau	> 35,000 psi at 4% Strain (after an initial strain to 8%)
Permanent Set after 8% Strain and Unloading	< 0.5%

## 8.0 Surface Finish and Appearance

8.1 Surface Finishes:

Order Code Suffix	Description	Appearance
-EMP	Etched & Mechanically Polished	Bright
-E	Etched Bright	Bright
-LO	Light Oxide	Gold to Brown
-P	Pickled	Dull Matt
-DK	Dark Oxide	Blue to Black
-BLK	Black Oxide	Shiny Black Color

---

# Nitinol #2 Wire

8.2 Wire must be clean of contaminants, smooth, free from bumps, kinks, waves, scrapes, splits, burrs and other surface defects.

## 9.0 Quality Assurance Provisions

9.1 Each lot of material is to be manufactured from a single source of raw material under known process conditions.

9.2 Supplier will be notified of any revision changes to this specification.

## 10.0 Certification and Spool Labeling

10.1 A certificate of compliance to this product number shall accompany each shipment.

10.2 Each spool shall be labeled with the:

- Product Type
- FWM Manufacturing or Production #
- Heat #
- FWM Part #
- Size
- Feet or Pounds (as applicable)

## 11.0 Packaging

11.1 The wire must be wound evenly on the spools, with no breaks or tangles.  
The maximum weight per spool shall be as follows unless specified otherwise on the purchase order.

Wire Size	Maximum Weight	Spool Type
0.0007" to 0.003"	0.5 pounds	2.5"x3", DIN80, DIN100, DIN125, Steeger, NE #2, Wardwell Bobbins
> 0.003" to < 0.012"	5 pounds	2.5"x3", DIN100, DIN125, Weldwire Reel
> 0.012" to 0.018"	10 pounds	Weldwire Reel
> 0.018" to 0.035"	20 pounds	Weldwire Reel

# Nitinol #4 Wire

## 1.0 Scope

1.1 This specification covers all necessary information for the purchasing of Nitinol #4 round wires having a diameter  $\geq 0.001''$  (0.025mm) and  $\leq 0.040''$  (1.016mm).

## 2.0 Product Definition

NiTi#4-CW Nitinol #4 Cold Worked

NiTi#4-SE Nitinol #4 Super-Elastic Straight Annealed

Add desired suffix to select oxide finish as described in Paragraph 8.1.

## 3.0 Applicable Documents

ASTM A555	Standard Specification for General Requirements for Stainless Steel Wire and Wire Rods
ASTM F2005	Standard Terminology for Nickel-Titanium Shape Memory Alloy
ASTM F2004	Standard Test Method for Transformation Temperature of Nickel-Titanium Alloys by Thermal Analysis
ASTM F2063	Standard Specification for Wrought Nickel-Titanium Shape Memory Alloys for Medical Devices and Surgical Implants
ASTM F2516	Standard Test Method for Tension Testing of Nickel-Titanium Super-Elastic Materials

## 4.0 Chemical Composition

4.1 The chemical composition of the material shall be equal to or better than those defined by ASTM F2063. FWM meets or exceeds the following chemical composition requirements:

Element	Weight %
Nickel . . . . .	54.5 to 57.0 (Reference)
Carbon . . . . .	< 0.050 (500 ppm maximum)
Cobalt . . . . .	< 0.050 (500 ppm maximum)
Copper . . . . .	< 0.010 (100 ppm maximum)
Chromium . . . . .	< 0.010 (100 ppm maximum)
Hydrogen . . . . .	< 0.005 (50 ppm maximum)
Iron . . . . .	< 0.050 (500 ppm maximum)
Niobium . . . . .	< 0.025 (250 ppm maximum)
Nitrogen plus Oxygen . . . . .	< 0.050 (500 ppm maximum)
Any Single Trace Element . . . . .	< 0.1
Total Trace Elements . . . . .	< 0.25
Titanium . . . . .	balance

# Nitinol #4 Wire

## 5.0 Transformation Properties

- 5.1 The fully annealed ingot austenite start ( $A_s$ ) temperature shall be  $-10^{\circ}\text{C}$  to  $+10^{\circ}\text{C}$  when measured by DSC in accordance with ASTM F2004.
- 5.2 Materials ordered in the Super-Elastic Straight Annealed (NiTi#4-SE) condition will have a finish  $A_f$  temperature between  $+14^{\circ}\text{C}$  to  $+22^{\circ}\text{C}$  when tested per FWM procedures.

## 6.0 Applicable Wire Sizes and Standard Tolerances

(in accordance with ASTM A 555)

Specified Size (inches)	Standard Tolerance (inches)
$\leq 0.040$ to $0.033$	$\pm 0.0008$
$< 0.033$ to $0.024$	$\pm 0.0005$
$< 0.024$ to $0.012$	$\pm 0.0004$
$< 0.012$ to $0.008$	$\pm 0.0003$
$< 0.008$ to $0.0048$	$\pm 0.0002$
$< 0.0048$ to $0.001$	$\pm 0.0001$

Notes: 1) Tighter tolerance available upon request  
2) Out of round tolerance shall be one-half the total size tolerance

## 7.0 Mechanical Properties

7.1 All Mechanical Testing Conducted at  $22^{\circ}\text{C} \pm 2^{\circ}\text{C}$

7.2 Cold Worked Wire (NiTi#4-CW)

The cold worked wire shall conform to the following mechanical properties:

Cold Work	45% +/- 5%
Ultimate Tensile Strength	200,000 psi minimum
Tensile Elongation at Failure	4% minimum (as measured by the above referenced document)

## 7.3 Super-Elastic Wire (NiTi#4-SE)

Ultimate Tensile Strength	180,000 psi
Elongation at Break	$> 10\%$
Loading Plateau	$> 65,000$ psi at 4% Strain
Unloading Plateau	$> 15,000$ psi at 4% Strain (after an initial strain to 8%)
Permanent Set after 8% Strain and Unloading	$< 0.5\%$

## 8.0 Surface Finish and Appearance

### 8.1 Surface Finishes:

Order Code Suffix	Description	Appearance
-EMP	Etched & Mechanically Polished	Bright
-E	Etched Bright	Bright
-LO	Light Oxide	Gold to Brown
-P	Pickled	Dull Matt
-DK	Dark Oxide	Blue to Black
-BLK	Black Oxide	Shiny Black Color

8.2 Wire must be clean of contaminants, smooth, free from bumps, kinks, waves, scrapes, splits, burrs and other surface defects.

## 9.0 Quality Assurance Provisions

9.1 Each lot of material is to be manufactured from a single source of raw material under known process conditions.

9.2 Supplier will be notified of any revision changes to this specification.

## 10.0 Certification and Spool Labeling

10.1 A certificate of compliance to this product number shall accompany each shipment.

### 10.2 Each spool shall be labeled with the:

Product Type  
FWM Manufacturing or Production #  
Heat #  
FWM Part #  
Size  
Feet or Pounds (as applicable)

## 11.0 Packaging

11.1 The wire must be wound evenly on the spools, with no breaks or tangles.

The maximum weight per spool shall be as follows unless specified otherwise on the purchase order.

Wire Size	Maximum Weight	Spool Type
0.001" to 0.003"	0.5 pounds	2.5"x3", DIN80, DIN100, DIN125, Steeger, NE #2, Wardwell Bobbins
> 0.003" to < 0.012"	5 pounds	2.5"x3", DIN100, DIN125, Weldwire Reel
> 0.012" to 0.018"	10 pounds	Weldwire Reel
> 0.018" to 0.035"	20 pounds	Weldwire Reel

# DFT® Wire

Magnified 200x 0.00894" in Diameter

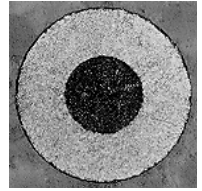

DFT wire is a metal-to-metal composite developed to combine the desired physical and mechanical attributes of two or more materials into a single wire or ribbon system. As a result of extreme compressive forces imparted during the processing of the dissimilar materials, the mechanical bond formed between surfaces has been found to be metallurgically sound. This feature has given rise to a number of novel applications of DFT wire, cable or ribbon.

One of the more common uses of DFT wire is found in the medical device industry, where designers have integrated the strength and biocompatibility of implant grade alloys with desired properties of other materials. The composite typically uses the outer sheath to impart strength, while the core material is designed to provide conductivity, radiopacity, resiliency or MRI enhancement.

DFT wire enables the unique ability to match dissimilar materials to provide a variety of properties in a single wire system. This technology can be utilized by the engineer to resolve technical issues cost effectively.

**Fig. 1**  
Typical tensile values for 35N LT-DFT wire with a silver core (% Ag)

% Cold Work	Pounds per square inch			
	25% Ag	28% Ag	33% Ag	41% Ag
0%	158,200	148,800	149,600	124,100
20%	201,300	191,200	192,600	162,800
37%	225,600	216,500	213,800	165,800
50%	237,300	227,300	224,700	192,400
61%	246,000	236,000	232,400	200,000
69%	256,700	244,000	239,300	206,400
75%	261,200	248,100	242,300	209,500
80%	267,800	254,500	249,300	214,900
84%	276,000	264,000	261,600	217,000
87%	278,200	264,300	262,300	225,000
90%	277,300	264,300	258,400	223,300
92%	281,900	266,900	254,700	232,200

**Fig. 2**  
Theoretical total resistance per foot for 35N LT-DFT wire with a silver core

Size	Ohms per foot				
	25% Ag	28% Ag	33% Ag	41% Ag	Solid 35N LT Wire
0.006	1.0132	0.9104	0.7788	0.6324	17.26
0.004	2.2797	2.0489	1.7521	1.4228	38.84
0.002	9.1126	8.1911	7.0064	5.6914	155.34
0.001	36.5347	32.7598	28.7598	22.7663	621.38

## Size

Fort Wayne Metals has the capability to create these DFT wire materials in sizes from .050" to .001" or smaller depending on the constituents.

## Values and Compositions

A typical 35N LT®/Silver DFT wire material (35N LT) may have a variety of tensile values depending upon the amount of cold work and core percentages of the individual wires (See Fig. 1). In addition, the table in Fig. 2 is presented to compare the electrical resistivity of various core percentages to that of solid 35N LT wire, a common pacemaker lead material.

35N LT, MP35N®, 316LVM and FWM 1058® tubing is kept in stock for the outer sheath. Core wire options, in wire form, are more abundant in general inventory.

Core Material	Tubing Materials
Gold	35N LT®
Silver	MP35N®
Platinum	316LVM
Titanium Alloys	Nitinol
Nitinol	FWM 1058®
Tantalum	Titanium Alloys
Platinum Alloys	
Tungsten	
Your Choice	

# Flat Wire

## Manufacturing Techniques

Flat wire, often referred to as ribbon wire, is commonly used in devices designed to reduce catheter profiles or increase available lumen size. Typical applications include safety wires in a catheter guidewire, helical coils in a catheter guidewire and braiding wire. Fort Wayne Metals uses two manufacturing techniques to yield different types of radius edged flat wire: rolled flat wire and drawn flat wire (see illustrations).

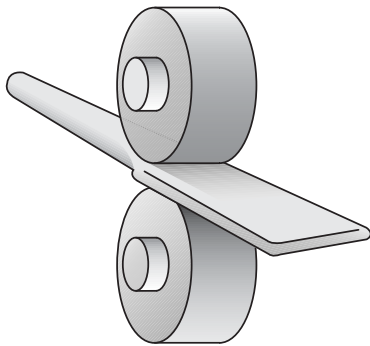

Rolled Flat Wire

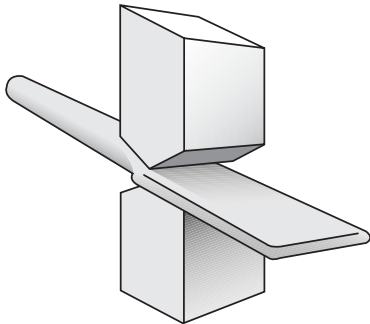

Drawn Flat Wire

## Flat Wire Comparisons

Both products exhibit a smooth bright surface finish and tight size tolerances. However, each has its advantages. Rolled flat wire has a larger cast, less camber (see Straightness), less stress induced in the wire and a lower cost versus drawn flat wire as the width/thickness ratio increases. While drawn flat wire has the advantage of improved size tolerances (see Standard Tolerances), it's often specified for applications requiring more consistent and tighter dimensions.

## Size Availability

The maximum available width for both types of flat wire depends on the thickness and the alloy. The maximum width/thickness ratio of rolled flat wire is approximately ten to one, alloy allowing. Rolled flat wire is available as thin as .0003". Drawn flat wire is available as thin as .0015".

Standard tolerances for each wire type are described below. Depending on width, thickness, alloy and width/thickness ratio, both drawn flat wire and rolled flat wire may be offered.

## Standard Tolerances

### Rolled Flat Wire

#### Thickness Tolerance

+/- 10% of the thickness rounded up to the next 0.0001", with a minimum of +/- 0.0002".

#### Width Tolerances

+/- 10% of the width rounded up to the next .0001".

### Drawn Flat Wire

Width or Thickness		Tolerance
Over	Including	+/-
0.0000"	0.0080"	0.0002"
0.0080"	0.0120"	0.0003"
0.0120"	0.0240"	0.0004"
0.0240"	0.0330"	0.0005"
0.0330"	0.0440"	0.0008"
0.0440"	—	0.0010"

## Tensile Strength

The tensile strength of flat wire is determined by manufacturing techniques. Tensile strength ranges from annealed to spring temper in most alloys. The maximum tensile strength is a function of both the alloy itself and other requirements of the specified wire, such as cast.

# Flat Wire

## Cross-Sectional Area Calculation

When determining tensile strength, it's necessary to properly calculate the cross-sectional area using the flat wire conversion factors (see chart on the back of this insert). Because both rolled and drawn flat wire have full radius edges (see illustration), necessary adjustments to remove the corners of the rectangle from the area calculation must be determined. Accurate calculation is vital because minute differences in cross-sectional area can make significant differences in tensile strength.

## Flat Wire Conversion Factors

The first column is width divided by thickness. The factor is to be used to calculate cross-sectional area (e.g.  $0.010" \div 0.003" = 3.3$ ; look up 3.3 to get 0.984;  $0.003" \times 0.010" \times 0.984 = 0.0000295$ ; this is the cross-sectional area).

**Flat Wire Conversion Factors**

Width Thickness	Factor	Width Thickness	Factor
1.1	0.836	3.0	0.981
1.2	0.867	3.1	0.982
1.3	0.890	3.2	0.983
1.4	0.907	3.3	0.984
1.5	0.920	3.4	0.985
1.6	0.930	3.5	0.986
1.7	0.939	3.6	0.987
1.8	0.946	3.7-3.8	0.988
1.9	0.952	3.9-4.0	0.989
2.0	0.957	4.1-4.2	0.990
2.1	0.961	4.3-4.4	0.991
2.2	0.964	4.5-4.7	0.992
2.3	0.968	4.8-5.0	0.993
2.4	0.970	5.1-5.5	0.994
2.5	0.973	5.6-6.0	0.995
2.6	0.975	6.1-6.9	0.996
2.7	0.977	7.0-8.1	0.997
2.8	0.978	8.2-10.0	0.998
2.9	0.980	> 10.0	0.999

## Secondary Cleaning Capabilities

Fort Wayne Metals uses various techniques to improve the surface cleanliness of flat wire. These include heat cleaning, solvent wipes and hot alkaline or ultrasonic-cleaning, used on their own or in various combinations.

## Straightness: Cast and Camber

If straightness is critical to the flat wire application, then a minimum cast and/or maximum camber may be specified. Cast is measured by cutting a three foot piece off the spool and laying it on its edge on a flat surface so it forms a circle or an arc. The size of the circle or arc is the cast. To determine camber, a short length of flat wire is cut. Next it is placed on its width rather than its edge. Then, by holding the wire in the middle against a straight line, the distance that the free ends extend from the line is measured as camber.

# Shaped Wire

## Shaped Wire

Shaped wire allows you to lower overall manufacturing and product costs by reducing assembly time and machining processes. This rolled wire provides a good cast and is available in all alloys. It is a near net shape product and is able to achieve unique geometries.

## Popular Shapes

### D-Wires



Half Round, Over Half Round and Under Half Round geometries can be achieved.

D-Wires are often used as the product or also as tooling.



D-Wires can provide unique lumen shapes in plastic components.

**Sizes:** as small as 0.0015" x 0.004" to 0.040" x 0.080".

### Angle Wires

Angle wires are classified as either pie or triangle.

Nearly any angle can successfully be achieved from approximately 45° to 120° and greater.



#### Pie Angle Sizes:

As small as 0.003" x 0.0045" to 0.030" x 0.045".



#### Triangle sizes:

As small as 0.0016" x 0.0021" to as large as 0.030" x 0.039" and possibly larger.



#### Rectangles and Square sizes:

Square: as small as 0.0025" x 0.0025" to 0.040" x 0.040".

Rectangle: as small as 0.005" x 0.008" to 0.030" x 0.040".

## Tolerances:

### Thickness

+/- 10% of the thickness rounded up to the next 0.0001", with a minimum of +/- 0.0002".

### Width

+/- 10% of the width rounded up to the next 0.0001".

## Tensile Strength

Tensile strength ranges from annealed to spring temper can be achieved in most shapes and alloys. Wires with unique geometries should be specified with a Break Load requirement, and use the tensile strength calculation as a reference due to the difficulty of measuring the cross sectional area.

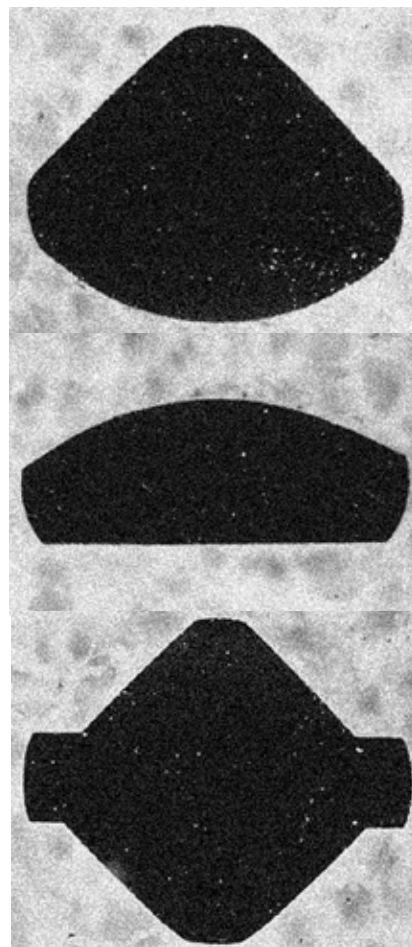

# Strands and Cables

Strands and cables are ideal for applications requiring more strength and flexibility than a single wire filament. These highly engineered products often utilize complex constructions or processes to enhance fatigue life, strength, flexibility, torque, stiffness and smoothness. Strands are manufactured by wrapping several filaments of wire together to form a single product. If several strands are wrapped together they form a single cable.

## Applications

Fort Wayne Metals manufactures medical grade multi-filament strands and cables in customized configurations for a variety of critical applications. Strands and cables can be offered on spools, in discrete lengths and fully assembled. End uses include:

Orthopaedic Cable Systems	Guidewires
Orthodontic Appliances	Bioconductors
Spinal Cable Systems	Embolus Protection
Endoscopic/Laparoscopic Instruments	Snares

## Alloy Selection for Cables

All of the raw materials we work with can be transformed into strands or cables. Biocompatibility, strength, fatigue, flexibility, torqueability and radiopacity are just a few items that might be considered during alloy selection. Our engineering staff can assist you in determining the appropriate alloy for your strand or cable application. Here is a small list of medical grade materials that are commonly used for strand and cable systems:

Ti 6Al-4V ELI	FWM 1058® Alloy
35N LT®	316LVM (316LS)
MP35N®	DFT®
L-605 (HAYNES® 25)	Nitinol (Binary & Ternary)
304V	22Cr-13Ni-5Mn
CP Ti Gr. 2	Ti 6Al-7Nb

## DFT® (Drawn Filled Tube) Strands & Cables

Multi-filament DFT material allows the device maker to match dissimilar materials to provide a variety of unique properties. One of the more common uses of DFT strands and cables is found in the medical device industry where designers have integrated the strength and biocompatibility of implant grade alloys with desired properties of other materials. The composite typically uses the outer sheath to impart strength while the core material is designed to provide conductivity, radiopacity, resiliency or MRI enhancement.

## Construction Capabilities

Aside from the typical strand and cables constructions (see illustrations on the following page), we also offer specialty constructions such as swaged, drawn strands and cables with tighter tolerances. We can work with you to create a specialty strand or cable that fits your unique application.

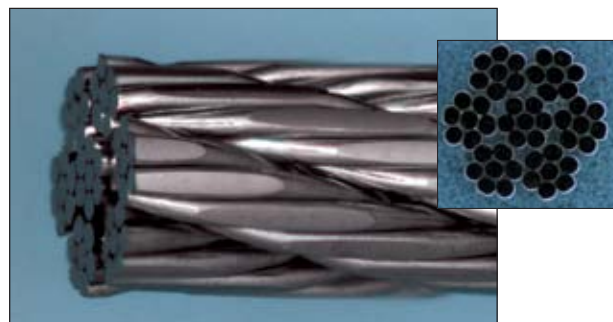

Swaged & Drawn Cable - These strands and cables offer a more tightly compacted structure with smoother surface characteristics. Break strength can also be increased within a drawn or swaged cable by compacting larger filament wires.

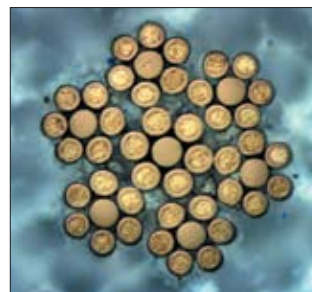

Drawn Filled Tube Cable – This is an example of 7 x 7 cable construction utilizing a combination of DFT and mono-filament wires.

# Strands and Cables

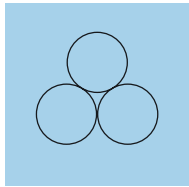

1 x 3 (3 wires)

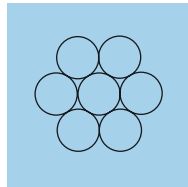

1 x 7 (7 wires)

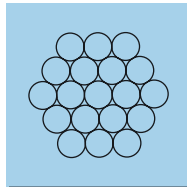

1 x 19 (19 wires)

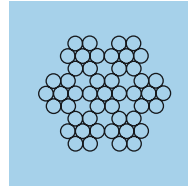

7 x 7 (49 wires)

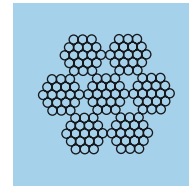

7 x 19 (133 wires)

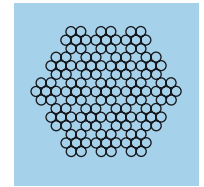

19 x 7 (133 wires)

## Size Availability & Tolerances

Fort Wayne Metals has the capability to manufacture strands and cables in a variety of sizes and constructions. Ranging from ultra fine or miniature strands with diameters below .004" to cables up to 0.125" in diameter. Tolerances can vary depending on diameter, construction, swaging, or drawing, therefore, please contact our technical staff with your requirements.

## Assembly

Our assembly room allows our customers the option of one stop shopping. Trained experts can perform a variety of value added manufacturing operations to enhance your strand or cable. Services include:

- |             |          |          |
|-------------|----------|----------|
| Beading     | Welding  | Grinding |
| Fusing      | Swaging  | Cutting  |
| Passivation | Crimping |          |

## Breakload & Tensile Strength

Through many years of experience, Fort Wayne Metals has collected and analyzed ultimate tensile strength and breakload (the force required to break the strand or cable under tension) mechanical data from various strand and cable configurations. Understanding both of these mechanical attributes aids in the design of a strand or cable.

## Strand and Cable Size and Capability

As a general guideline Fort Wayne Metals can strand wires with filament diameters down to .001".

Construction	Finished Diameter	Flexibility	Torque
1 x 3	2.15 x d	Lowest	Greatest
1 x 7	3 x d		
1 x 19	5 x d	Greatest	Lowest
7 x 7	9 x d		
7 x 19	15 x d		
19 x 7	15 x d		

d= diameter of single filament

## Coatings

Fort Wayne Metals offers a variety of biocompatible coatings that provide insulation for strands and cables. Common coatings include ethylene tetrafluoroethylene (ETFE), polytetrafluoroethylene (PTFE) and perfluoro-alkoxy (PFA).

## Cleaning

Most strand and cable systems manufactured at Fort Wayne Metals take advantage of our stringent cleaning techniques. Strands and cables have the ability to trap contaminants once the wire filaments have been grouped together. We pride ourselves on removing these contaminants (oil, dirt, dust, etc.) through a variety of cleaning steps, which include isopropyl alcohol wipe, hot alkaline cleaning and ultrasonic cleaning. Our technical staff will be glad to help you determine which cleaning method will work best with your application.

# HHS<sup>®</sup> Tube



Fort Wayne Metals HHS Tube (Helical Hollow Strand) furthers our excellence in stranding and cabling of medical grade wire.

## Features and Benefits

HHS Tube is a stranded wire with an open center working channel which can be constructed of numerous material types all drawn on site. HHS Tube designs are tailored to customer specifications of dimension, tension, compression, torque, and pitch direction while exhibiting high kink resistance and excellent whip free characteristics. Single, dual and triple layer HHS Tube can be manufactured for varying flexibility and control with differing filar counts and sizes per layer.

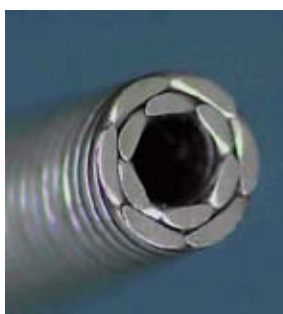

Dual layer HHS Tube

## Applications

- |                          |                         |
|--------------------------|-------------------------|
| Over the Wire Device     | Catheter Devices        |
| Manipulation Components  | Delivery Devices        |
| Working Channels         | Urological Tools        |
| Endovascular Devices     | Neurological Components |
| Minimally Invasive Tools | Bioconductors           |

## Specification

Helical Hollow Strands are designed using solid modeling according to mathematical formulas. Using parametric design, many design considerations can be evaluated in a short time. Materials are normally spring temper. Nitinol HHS is provided in the superelastic condition.

Flexibility can be influenced by design variables including ID, OD, Wire Size, Filar Count and other processing.

Inside Diameter: 0.001" (0.0254mm) to 0.130" (3.302mm)

Outside Diameter: 0.0025" (0.0635mm) to 0.160" (4.064mm)

Filars 6 to 18

Layers 1 to 3 (more may be available)

Lengths from 1' to 10' (longer possible depending on design)

Pitch Left, Right, Unidirectional, Reverse

## Secondary Operations

Customer specified performance testing:

Droop, Compression, Yield (elongation at load) or Torque

- |                 |                           |            |
|-----------------|---------------------------|------------|
| Square cut ends | Chamfering                | Formed HHS |
| Welding         | OD Step Grinding          | Soldering  |
| Taper Ground    | Coatings (see spec sheet) | Assembly   |

## Materials

See specification sheets for more information.

- |                     |                           |         |
|---------------------|---------------------------|---------|
| 302                 | 304V                      | 316L    |
| 35N LT <sup>®</sup> | DFT <sup>®</sup>          | L-605   |
| CP Titanium         | Ti 6Al-4V ELI             | Nitinol |
| Pt Alloys           | (Others may be available) |         |

Characteristics	HHS Tube	Coil	
		Unifilar	Multifilar
Torque	Excellent	Poor	Good
Windup (Low)	Good	Poor	Poor
Whip	Excellent	Excellent	Excellent
Pushability	Excellent	Excellent	Good
Use Tension	Excellent	Poor	Good
Compression (%)	Good	Excellent	Poor
Hoop Strength	Good	Excellent (Tight Wound)	Good
Wall Thickness (thinwall)	Good	Excellent	Excellent

# HHS Tube

## HHS Tube General Parameters

Parameter	Change	Flexibility	Pushability	Kink Resistance	Tensile Capability	Torque
Filar Diameter <sup>1</sup>	▲	▼	▼	▼	▲	▲
Filar Number <sup>2</sup>	▲	▼	▲	▼	▲	▲
Inside Diameter <sup>3</sup>	▲	▲	▼	▲	▼	▼
Material Modulus	▲	▼	▲	▼	■	▲
Drawn/Swage Secondary	OD▼	▼	▲▲	▼	▲▲	▲▲

Example: As the filar size (Filar Diameter) is increased (Change) there will be a loss in Flexibility and Kink Resistance but an increase in Pushability, Tensile Capability, and Torque.

Notes: 1. Results in longer lay (greater pitch), OD will increase 2. Results in longer lay (greater pitch), OD will remain constant 3. Results in shorter lay (shorter pitch), OD will increase

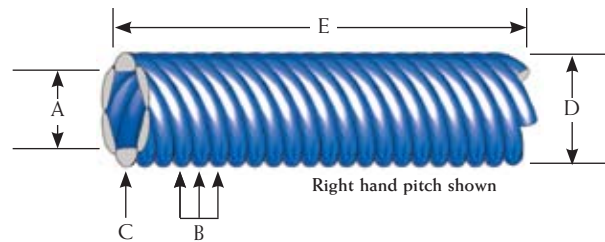

## Single Layer HHS Tube Description:

	A	B	C	D	E	
	Inside Diameter	Number of Filars	Filar Diameter	Outside Diameter	Length	
Range	Min.	0.001" 0.0254mm	6	0.0005" 0.0127mm	0.0025" 0.0635mm	1.0" 25.4mm
	Max.	0.130" 3.30mm	18	0.020" 0.50mm	0.160" 4.06mm	10' 3.05M



Single Layer



Dual Layer

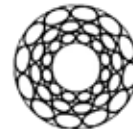

Triple Layer

Fort Wayne Metals' SLT medical grade wire combines excellent straightness and torqueability, directly off the spool or when cut to length. SLT wire eliminates the need for further straightening operations.

## Features and Benefits

SLT wire offers properties unique from other spooled wire by providing straightness directly off the spool with a deviation of less than .020" in 12" (0.5mm in 300mm). Due to the straightness of the wire, only negligible whip is experienced in the distal end when torque is applied to the proximal end. SLT wire also offers the ease of grinding to very small diameters, depending on the type of grinding processes used.

## Applications

Fort Wayne Metals manufactures SLT wire for many different situations where straightened wire was previously used. Applications may include: guidewires, suture needles, stylets and mandrel wires. SLT wire will also have uses in the fields of orthodontics and orthopaedics.

## Coating

Fort Wayne Metals offers a variety of biocompatible coatings that can be applied to SLT wire. Common coatings include ethylene tetrafluoroethylene (ETFE), polytetrafluoroethylene (PTFE) and perfluoroalkoxy (PFA).

## Shelf Life

SLT wire has currently been tested in various diameters and spool types for as long as ten months. No evidence of change has been observed in axial mechanicals and no degradation of straightness has been seen. Only a slight decrease in tensile strength, less than 2%, has been noted.

## Specification

In cases where no specification exists, the customer may find it helpful to follow this layout to create their own part number. Below is the optional part number layout:

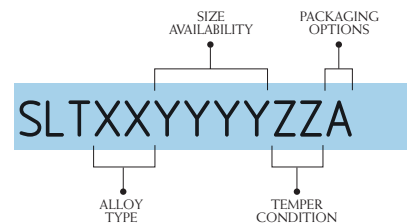

As an example, part number SLT4V0283FH2 would describe SLT wire that is produced from alloy 304V, with a diameter of .0283", at the full hard condition, and packaged on a DIN160 spool. In the sections listed below the corresponding letters and part number codes are described.

## Alloy Selection for SLT Wire (XX)

Fort Wayne Metals offers various types of medical grade wire that can be transformed into SLT wire. Our engineering staff can assist you in making an alloy decision that best suits your application.

The list below contains some alloys that may be used for SLT wire along with the corresponding part number codes. Please check with Fort Wayne Metals technical staff for other available alloy options.

Alloy Type	Code (XX)
304V	4V
304LV	4L
302	32
301	31
35N LT*	35
316LVM	6L

## Size Availability (YYYY)

Fort Wayne Metals offers SLT wire in a variety of diameters from .003" to approximately .035". More diameter options may be available. Please contact your customer service associate for more information. For a diameter of .0283" (.72mm) the corresponding part number code would be YYYYY = 0283.

# SLT Wire

## Temper Condition (ZZ)

SLT wire can also be produced in many different temper conditions. Listed below are some examples along with the corresponding order codes. Please note that all conditions may not be available at certain diameters.

Temper Condition	Code (ZZ)
3/4 Hard	3H
Full Hard	FH
Spring	SP
Double Spring	DS
Ultra Spring	UP
Hyten	HY

## Packaging Options (A)

Fort Wayne Metals offers several different packaging options for SLT wire. Our packaging ensures that the quality of our wire is protected while en route to our customers. Depending on the diameter size of the SLT wire, certain spools may be more beneficial than others. Please ask Fort Wayne Metals technical staff for recommendations. Below is a list of a few of the spool types offered for SLT wire and the corresponding recommended wire sizes:

Spool	Wire Diameter Inches (mm)	Flange Diameter Inches (mm)	Hub Diameter Inches (mm)	Traverse Length Inches (mm)	Bore Diameter Inches (mm)	Code (A)
DIN160	Up to .005" (0.127mm)	6.3" (160mm)	3.9" (99mm)	5.0" (127mm)	0.87" (22mm)	2
Weld Wire Reel	.006" - .0236" (0.15 - 0.6mm)	11.7" (297mm)	8.3" (211mm)	3.62" (92mm)	2.0" (50.8mm)	3
13.75" x 2.56"	.006" - .0365" (0.15 - 0.927mm)	13.75" (349mm)	11.0" (279mm)	2.5" (63.5mm)	2.0" (50.8mm)	4
K355	.013" - .0283" (0.33 - 0.72mm)	13.98" (355mm)	8.82" (224mm)	6.3" (160mm)	1.42" (36mm)	5
SH 370K Reel	.0283" - .0365" (0.72 - 0.927mm)	14.57" (370mm)	12.24" (311mm)	2.76" (70mm)	12.0" (305mm)	6

NDR is an acronym: Nanograin Damage Resistant. NDR is a process which comprises a thermal-mechanical treatment designed to produce nanoscale microstructural refinement. This refinement is evidenced by a significant increase in the material's ability to resist damage during high cycle mechanical loading, as encountered, for example, during the service of a long-term cardioverter defibrillator lead implant due to pulsating stresses.

## Typical Alloys

The NDR process may be applied to non-precipitation hardening, non-sensitizing, implant-grade alloys such as those called out by ASTM F562 alloy (35N LT<sup>®</sup> wire or MP35N<sup>®</sup> wire), ASTM F1058 (FWM 1058<sup>®</sup> wire) and ASTM F138 (316LVM).

## Typical Fatigue Results<sup>1</sup>

	Fatigue Strength <sup>2</sup> , GPa (ksi)		
	Standard	NDR Wire	Change
ASTM F562 (35N LT)	0.83 (120)	1.1 (165)	38%
ASTM F1058 (FWM 1058)	0.59 (85)	0.86 (125)	47%
ASTM F138 (316LVM)	0.48 (70)	0.67 (98)	40%
ASTM A580 (304LV)	0.65 (95)	0.86 (125)	32%

1. Typical results for 0.18 mm (.007") drawn wire. While these results are typical, they represent data from a single laboratory exercise and will not translate directly to each application.
2. Fatigue Strength: stress amplitude in a fully reversed rotary beam fatigue test at  $1 \times 10^7$  cycles calculated using published moduli for each alloy.

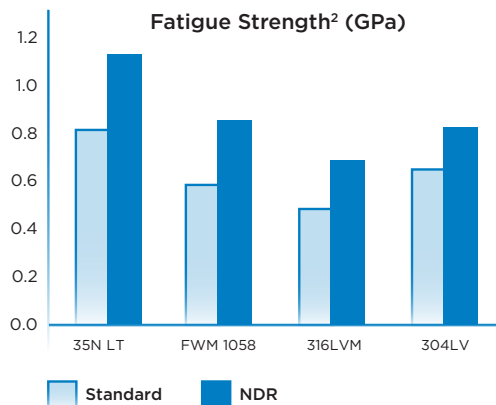

## Physical Properties

NDR processing does not change the chemical or atomic makeup of the parent alloy system. Properties such as density, electrical resistivity, thermal conductivity and thermal coefficient of expansion are similar before and after the application of NDR technology.

## High Performance

The performance of NDR wire is attributable to the underlying microstructure. Conventional microstructure is shown below (left), where the average breadth of each grain is 2 microns. The next image (right) shows NDR-refined microstructure where similar features are on the order of 200 nm.

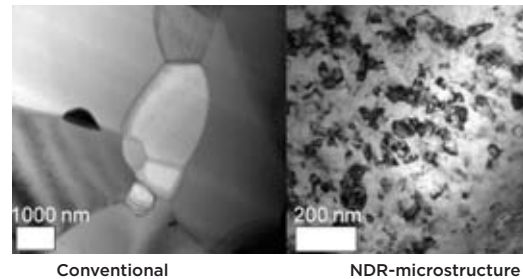

## Example Mechanical Properties

The tensile mechanical properties of NDR wire are similar to conventional wire. Three examples of possible properties for 35N LT alloy are given below.

## Example Mechanical Properties

	35N LT NDR Wire			35N LT Conventional Wire		
	ANLD	Hard	Spring	ANLD	Hard	Spring
Ultimate Strength GPa (ksi)	1.45 (210)	1.79 (260)	2.21 (320)	1.31 (190)	1.79 (260)	2.21 (320)
0.2% Yield Strength GPa (ksi)	1.31 (190)	1.45 (210)	2.00 (290)	0.69 (100)	1.45 (210)	2.00 (290)
Rupture Strain (%)	15	4	2	35	4	2
Fatigue Strength GPa (ksi)	1.14 (165)	1.21 (175)	1.14 (165)	0.62 (90)	0.83 (120)	0.93 (135)

# Laser Ablation

Laser ablation, or laser wire stripping, is a non-mechanical means to remove the coating from select locations on a given wire substrate. The result will be a clean and undamaged wire that has not been marred by mechanical cutting blades. Laser ablation provides greater flexibility in locating the areas of coating removal which allow for more complex components. Fort Wayne Metals' ablation process will accommodate spooled and cut length materials and will provide discrete lengths ready to use.

## Lead-Times

Our in-house laser ablation capabilities allow us to offer a more stream-lined manufacturing approach for coated wire and cable needs. Fort Wayne Metals now offers a fully integrated manufacturing option for our customers through utilization of our wire drawing, stranding, coating, and laser ablation.

Features:	Applications:
Tight tolerances	Cardiac Rhythm Management
Precision transition zones	Neurostimulation
Discrete lengths	Guidewires
Processing from a spool or discrete pieces	Electrophysiology
	End Terminations

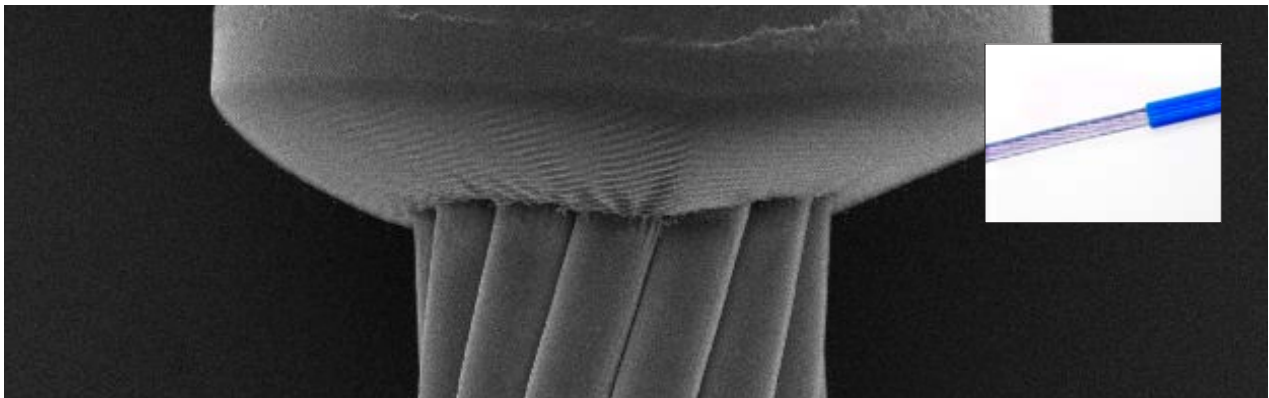

Wire Types	Sizes	Coating Types	Coating Thickness	Lengths	Ablation Locations	Ablation Lengths
Solid Strand Cable	Min 0.002" (0.05mm)	ETFE PTFE PFA FEP and others	Min 0.0002" (0.005mm)	Max 80" (2.03m)	Beginning End Variable	Min 0.004" (0.102mm)
	Max 0.050" (1.27mm)		Max 0.005" (0.127mm)			Variable lengths on given components

# Packaging & Spooling

## Packaging Options

When it comes to packaging, Fort Wayne Metals is very flexible, providing a variety of options. Our packaging ensures that the quality of our wire is protected while en route to our customers.

When it comes to spools, you can specify the spool type you want, or let us recommend the one we feel will work best for your specific needs. For additional protection on alloys that are subject to corrosion, spools can be bagged with desiccant packets.

Straightened and cut wire is shipped in PVC tubes or wood crates, depending on the quantity. And as in everything we do, customer satisfaction is our main goal.

## Labeling of Spools

An integral part of our packaging process is quality control through spool labeling. Standard information including alloy type, size, lot number, spool net weight, customer purchase order number, date and spool number is listed on each spool



(excluding braiding bobbins) before it leaves our premises. To help ensure accurate information, the statistical average of mechanical properties flows directly from internal data collection to labels.

The label also indicates the average break load, ultimate tensile strength and percent elongation of the wire, based on our sampling plan. And you also have the option of having your spools 100% inspected and labeled.

Spool	Flange	Hub	Traverse	Bore	Weight	Diameter	Spool Composition
22 x 11	22.00	14.00	11.00	5.00	500.00	>=.050	Polystyrene
18 x 10	18.00	11.00	9.60	5.00	200.00	>=.050	Polystyrene
12 x 6	12.00	6.00	6.00	1.30	40.00	>.012	Lexan/ABS
Weld Wire	11.70	8.30	3.62	2.00	20.00	>.012	Polyethelene
8 x 6	8.00	4.60	6.00	1.20	20.00	>.012	ABS
6 x 3.5	6.00	3.50	3.50	0.62	10.00	.004 - .0199	ABS
4.5 x 3	4.50	2.50	3.00	0.62	5.00	.003 - .010	ABS
2.5 x 3	2.50	1.70	3.00	0.62	1.00	<=.003	ABS
DIN80	3.20	2.00	2.50	0.63	1.00	<=.003	ABS
DIN100	3.90	2.50	3.10	0.63	3.00	.003 - .005	ABS
DIN125	4.90	3.10	3.90	0.63	5.00	.004 - .010	ABS
DIN160	6.30	3.90	5.00	0.87	10.00	.010 - .020	ABS
DIN250	9.80	6.30	6.30	0.87	20.00	>.012	ABS
Wardwell Bobbin	2.60	1.30	2.80	1.10 Spline	0.50	<=.003	Nylon
Steeger Braider Bobbin	1.56	0.62	1.10	0.41	0.25	<=.003	ABS
New England #2 Braider Bobbin	1.70	0.62	2.50	0.30	0.50	<=.003	Nylon

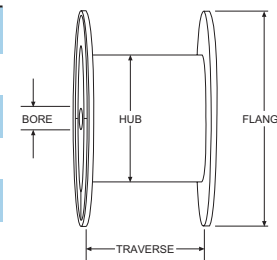

All dimensions shown are in inches.

---

# Packaging & Spooling

## Custom Spooling

Another option is custom spooling. We have the ability to custom spool any specific length of wire. In addition, we can adapt our equipment to work in conjunction with any custom spool you supply.

## Ecological and Financial

### **Return on Investment**

In order to minimize ecological and financial costs to both our environment and our customers, we've implemented a spool return policy. We'll refund 50% of the deposit on all spools returned to us in good condition, freight prepaid. Most of our spools are made using a virgin ABS (Acrylonitrile Butadiene Styrene). This is the strongest, most consistent dimensionally of all polymer spools. However, if returned spools are unfit for reuse, they're returned to the spool manufacturer to be ground up and used in other spool manufacturing.

We'll also accept any broken or bad spools as a part of our recycling program. This program recycles the various spool compositions to the manufacturers in order to reduce the number of recyclable products being taken to landfills. All of our packaging is now manufactured using recycled cardboard and is printed with water-soluble inks.

# Biomedical Coatings

Fort Wayne Metals has the ability to provide a variety of coated wire and cable configurations comprising a biocompatible sheath, lubricious barrier, or other medical grade material of your choice. It is common for Fort Wayne Metals to work with bioconductors that require an isolated electrical signal. In these instances, selection of the appropriate dielectric material is critical. Our engineering team can assist with the selection and design of any coating configuration. Electrical insulation is just one of many reasons why coatings are applied for wire based medical applications. Other considerations may include: chemical isolation, lubricity, or surface preparation. Fort Wayne Metals is always open to exploring new coatings for a variety of medical applications.

## Fluoropolymers:

Ethylene-Tetrafluoroethylene (ETFE), Perfluoroalkoxyethylene-Tetrafluoroethylene (PFA) and Fluorinated Ethylene Propylene (FEP) are all copolymers of Tetrafluoroethylene (TFE). Each material combines the chemical inertness of Polytetrafluoroethylene (PTFE) with another polymer to provide melt forming capability and strength. All three fluoropolymers are utilized in a variety of medical device applications due to their excellent dielectric strength, chemical resistance and mechanical toughness. Alternate coatings will be considered upon request.

**ETFE** possesses the greatest strength and abrasion resistance of the TFE copolymers. ETFE has a continuous service temperature range of 150°C.

**PFA** is most similar in terms of chemical and physical behavior to PTFE. PFA has the added benefit of a higher service temperature (260°C) over FEP.

**FEP** is similar in chemical and physical behavior to PFA. It possesses a lower service temperature (200°C) and is

slightly less susceptible to water absorption than most other fluoropolymers.

## Colorants:

Fort Wayne Metals can offer a wide variety of color concentrates. Standard colors include blue, white, red, green, yellow, orange and black. Additional colors available upon request.



## Coating Capabilities:

**Round Wire Sizes:** .002" to .020"

**Strands & Cable Sizes:** .003" to .060"

**Wall Thickness:** Typically range from .005" to less than .0005"

**Coating Substrates:** Coatings can be applied to round wire and strands and cables in any alloy or material system we offer.

**Configurations:** Round or Shaped Wires, Strands and Cables.

## Features:

Biocompatible	Thin Wall
Custom Packaging	Pin Hole Free
Medical Focus	Excellent Dielectric Strength
Tight Tolerances	

## Lead Times:

Our in-house coating capabilities allow us to offer a more stream-lined manufacturing approach for wire and cable needs. Fort Wayne Metals can now offer a fully integrated manufacturing option for our wire and cable customers, thus eliminating inefficiencies associated with transferring material to multiple manufacturing sites.

## Typical properties of extruded thermoplastics

Name	Density [g/cc]	Typical Tensile Strength [Mpa / psi]	Coefficient of Friction	Dielectric Strength [kV/mm V/mil]	CTE @ 20°C [µm/m-°C]	Water Absorption [%]	Max. Service Temperature in Air [°C]
ETFE	1.70	41 / 6000	0.23	64 / 1600	130	.006	150
PFA	2.15	28 / 4000	0.21	62 / 1575	140	.050	260
FEP	2.15	25 / 3600	0.25	62 / 1575	140	.005	200
PTFE*	2.20	24 / 3500	0.10	58 / 1470	100	.004	270

These properties are for reference only and can vary significantly dependent on processing conditions and material grade. \*PTFE is not a melt-processable thermoplastic.

# PTFE Coatings



Fort Wayne Metals provides PTFE<sup>1</sup> based coatings and coating compositions on wires for a variety of medical applications. LubriSkin™ and DuraSkin™ PTFE dispersion coatings are applied to medical wires to increase lubricity and chemical

resistance. The proprietary spool-to-spool process employed delivers a lower coefficient of friction than spray coating techniques. LubriSkin is the preferred coating for coiling wire applications and mandrels. DuraSkin is recommended for coating SLT<sup>®</sup> wire, Fort Wayne Metals' straight linear one-to-one torque wire, which is used for PTCA guidewires and stylets.

## PTFE Coatings

	DuraSkin	LubriSkin
<b>Coating thickness</b>	Standard: 4 - 10 µm (0.00016 - 0.00039")	Standard: 4 - 10 µm (0.00016 - 0.00039")
<b>Colors</b>	Green, Gray, Blue, Black, White, Clear	Green, other colors on request
<b>Primary Uses</b>	Corewires; (PTCA) Extrusion Mandrel Wire	Coiling Wire, Bonding Mandrels, Release Mandrels
<b>Supplied</b>	Straightened & Cut Lengths, Spooled	Straightened & Cut Lengths, Spooled
<b>Gamma Stable</b>	Yes	No
<b>ETO sterilization</b>	Yes	Yes
<b>Biocompatibility</b>	For invasive techniques, but not for permanent human implants	For invasive techniques, but not for permanent human implants
<b>Heat Stability</b>	Up to 195° C (390° F).	Up to 205° C (400° F).
<b>Chemical Resistance</b>	Sensitive to some solvents like NMP, acetone, MEK etc.	Good - excellent
<b>Relative friction (uncoated SS = 1)</b>	0.45	0.40
<b>Dielectric Strength</b>	Not intended for electrical insulation	Not intended for electrical insulation

## LubriSkin

This proprietary coating process produces a smooth, uniform coated wire for the production of guidewires. This process is unique in that the wire is coated before it is coiled. The resulting precoated guidewire has a consistent LubriSkin coating, unlike conventional spray coated guidewires that often encounter cracking and flaking of the coating.

The LubriSkin coating is available in a variety of colors and on round or flat wire.



Competition spray coated coil



LubriSkin precoated coil

## DuraSkin

Our proprietary spool-to-spool process provides extremely uniform coating for medical device components. With excellent control over the coating thickness, we are able to guarantee tight tolerances.

Typical products include dead-straight stylets for PTCA guidewires, guidewire cores and catheter stylets using our SLT wire. This wire provides excellent one-to-one torque properties.

These PTFE coatings can be applied to our stainless steel range of alloys, our super alloys and to our Nitinol wires without compromising their elastic properties.

Please note our proprietary coating process increases the tensile strength of non-aged 304V by approximately 20ksi (140 MPa).

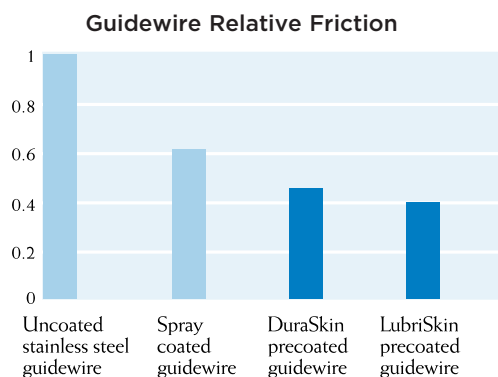

The graph above shows relative physical resistance of coated wire passing through human tissue according to coating type.

<sup>1</sup>PTFE, Polytetrafluoroethylene is a synthetic fluoropolymer

<sup>2</sup>LubriSkin and DuraSkin are registered trademarks of MCTec BV of Van Coehoornstraat 7, 5916 PH, Venlo, The Netherlands

# Stainless Steel Wire Conversion Chart

UNS 30400, UNS 31600 (TYPES 304, 316)

Boldface indicates AWG sizes

Dia. (In)	Area (In <sup>2</sup> )	Ft/Lb
.0010	.00000079	371,022
.0011	.00000095	306,630
.0012	.00000113	257,654
.0013	.00000133	219,540
.0014	.00000154	189,297
.0015	.00000177	164,899
.0016	.00000201	144,930
.0017	.00000227	128,381
.0018	.00000254	114,513
.0019	.00000284	102,776
<b>.0020</b>	<b>.00000314</b>	<b>92,756</b>
.0021	.00000346	84,132
<b>.0022</b>	<b>.00000380</b>	<b>76,657</b>
.0023	.00000415	70,136
.0024	.00000452	64,414
<b>.0025</b>	<b>.00000491</b>	<b>59,364</b>
.0026	.00000531	54,885
.0027	.00000573	50,895
<b>.0028</b>	<b>.00000616</b>	<b>47,324</b>
.0029	.00000661	44,117
.0030	.00000707	41,225
<b>.0031</b>	<b>.00000755</b>	<b>38,608</b>
.0032	.00000804	36,233
.0033	.00000855	34,070
.0034	.00000908	32,095
<b>.0035</b>	<b>.00000962</b>	<b>30,288</b>
.0036	.00001018	28,628
.0037	.00001075	27,102
.0038	.00001134	25,694
.0039	.00001195	24,393
<b>.0040</b>	<b>.00001257</b>	<b>23,189</b>
.0041	.00001320	22,072
.0042	.00001385	21,033
.0043	.00001452	20,066
.0044	.00001521	19,164
<b>.0045</b>	<b>.00001590</b>	<b>18,322</b>
.0046	.00001662	17,534
.0047	.00001735	16,796
.0048	.00001810	16,103
.0049	.00001886	15,453
<b>.0050</b>	<b>.00001964</b>	<b>14,841</b>
.0051	.00002042	14,265
.0052	.00002124	13,721
.0053	.00002206	13,208
.0054	.00002290	12,724
.0055	.00002376	12,265
<b>.0056</b>	<b>.00002453</b>	<b>11,831</b>
.0057	.00002552	11,420
.0058	.00002642	11,029
.0059	.00002734	10,658
.0060	.00002827	10,306
.0061	.00002922	9,971
.0062	.00003019	9,652
<b>.0063</b>	<b>.00003117</b>	<b>9,348</b>
.0064	.00003217	9,058
.0065	.00003318	8,782
.0066	.00003421	8,517
.0067	.00003526	8,265
.0068	.00003632	8,024
.0069	.00003739	7,793
<b>.0070</b>	<b>.00003848</b>	<b>7,572</b>
.0071	.00003959	7,360
.0072	.00004072	7,157
.0073	.00004185	6,962
.0074	.00004301	6,775
.0075	.00004418	6,596
.0076	.00004536	6,424
.0077	.00004657	6,258
.0078	.00004779	6,098
<b>.0079</b>	<b>.00004902</b>	<b>5,945</b>
.0080	.00005027	5,797
.0081	.00005153	5,655
.0082	.00005281	5,518
.0083	.00005411	5,386
.0084	.00005542	5,258
.0085	.00005675	5,135

Dia. (In)	Area (In <sup>2</sup> )	Ft/Lb
.0086	.00005890	5,017
.0087	.00005945	4,902
.0088	.00006082	4,791
<b>.0089</b>	<b>.00006221</b>	<b>4,684</b>
.0090	.00006362	4,581
.0091	.00006504	4,480
.0092	.00006648	4,384
.0093	.00006793	4,290
.0094	.00006940	4,199
.0095	.00007088	4,111
.0096	.00007238	4,026
.0097	.00007390	3,943
.0098	.00007543	3,863
.0099	.00007698	3,786
<b>.0100</b>	<b>.00007854</b>	<b>3,710</b>
.0101	.00008012	3,637
.0102	.00008171	3,566
.0103	.00008332	3,497
.0104	.00008495	3,430
.0105	.00008659	3,365
.0106	.00008825	3,302
.0107	.00008992	3,241
.0108	.00009161	3,181
.0109	.00009331	3,123
.0110	.00009503	3,086
.0111	.00009677	3,011
.0112	.00009852	2,958
<b>.0113</b>	<b>.00010029</b>	<b>2,906</b>
.0114	.00010207	2,855
.0115	.00010387	2,805
.0116	.00010568	2,757
.0117	.00010751	2,710
.0118	.00010936	2,665
.0119	.00011122	2,620
.0120	.00011310	2,577
.0121	.00011499	2,534
.0122	.00011690	2,493
.0123	.00011882	2,452
.0124	.00012076	2,413
.0125	.00012272	2,375
<b>.0126</b>	<b>.00012469</b>	<b>2,337</b>
.0127	.00012668	2,300
.0128	.00012868	2,265
.0129	.00013070	2,230
.0130	.00013273	2,195
.0131	.00013478	2,162
.0132	.00013685	2,129
.0133	.00013893	2,097
.0134	.00014103	2,066
.0135	.00014314	2,086
.0136	.00014527	2,006
.0137	.00014741	1,977
.0138	.00014957	1,948
.0139	.00015175	1,920
.0140	.00015394	1,892
.0141	.00015615	1,866
<b>.0142</b>	<b>.00015837</b>	<b>1,840</b>
.0143	.00016061	1,814
.0144	.00016287	1,789
.0145	.00016513	1,765
.0146	.00016742	1,741
.0147	.00016972	1,717
.0148	.00017203	1,694
.0149	.00017437	1,671
.0150	.00017671	1,649
.0151	.00017908	1,627
.0152	.00018146	1,606
.0153	.00018385	1,585
.0154	.00018627	1,564
.0155	.00018870	1,544
.0156	.00019113	1,525
.0157	.00019359	1,505
.0158	.00019607	1,486
<b>.0159</b>	<b>.00019856</b>	<b>1,468</b>
.0160	.00020106	1,449
.0161	.00020358	1,431

Dia. (In)	Area (In <sup>2</sup> )	Ft/Lb
.0162	.00020612	1,414
.0163	.00020867	1,396
.0164	.00021124	1,379
.0165	.00021382	1,363
.0166	.00021642	1,346
.0167	.00021904	1,330
.0168	.00022167	1,315
.0169	.00022432	1,299
.0170	.00022698	1,284
.0171	.00022966	1,269
.0172	.00023235	1,254
.0173	.00023506	1,240
.0174	.00023779	1,225
.0175	.00024053	1,212
.0176	.00024328	1,198
.0177	.00024606	1,184
.0178	.00024885	1,171
<b>.0179</b>	<b>.00025165</b>	<b>1,158</b>
.0180	.00025447	1,145
.0181	.00025730	1,133
.0182	.00026016	1,120
.0183	.00026302	1,108
.0184	.00026590	1,096
.0185	.00026880	1,084
.0186	.00027172	1,072
.0187	.00027465	1,061
.0188	.00027759	1,050
.0189	.00028055	1,039
.0190	.00028353	1,028
.0191	.00028652	1,017
.0192	.00028953	1,006
.0193	.00029255	996
.0194	.00029559	986
.0195	.00029865	976
.0196	.00030172	966
.0197	.00030481	956
.0198	.00030791	946
.0199	.00031103	937
.0200	.00031416	928
<b>.0201</b>	<b>.00031731</b>	<b>918</b>
.0202	.00032047	909
.0203	.00032365	900
.0204	.00032685	892
.0205	.00033006	883
.0206	.00033329	874
.0207	.00033654	866
.0208	.00033979	858
.0209	.00034307	849
.0210	.00034636	841
.0211	.00034967	833
.0212	.00035299	826
.0213	.00035633	818
.0214	.00035968	810
.0215	.00036305	803
.0216	.00036644	795
.0217	.00036984	788
.0218	.00037325	781
.0219	.00037668	774
.0220	.00038013	767
.0221	.00038360	760
.0222	.00038707	753
.0223	.00039057	746
.0224	.00039408	739
.0225	.00039761	733
<b>.0226</b>	<b>.00040115</b>	<b>726</b>
.0227	.00040471	720
.0228	.00040828	714
.0229	.00041187	708
.0230	.00041548	701
.0231	.00041910	695
.0232	.00042273	689
.0233	.00042638	683
.0234	.00043005	678
.0235	.00043374	672
.0240	.00045239	644
.0245	.00047144	618

Dia. (In)	Area (In <sup>2</sup> )	Ft/Lb
.0250	.00049087	594
<b>.0253</b>	<b>.00050273</b>	<b>580</b>
.0255	.00051071	571
.0260	.00053093	549
.0265	.00055155	528
.0270	.00057255	509
.0275	.00059396	491
.0280	.00061575	473
<b>.0285</b>	<b>.00063794</b>	<b>457</b>
.0290	.00066052	441
.0295	.00068349	426
.0300	.00070688	412
.0305	.00073062	399
.0310	.00075477	386
.0315	.00077931	374
<b>.0320</b>	<b>.00080425</b>	<b>362</b>
.0325	.00082958	351
.0330	.00085530	341
.0335	.00088141	331
.0340	.00090799	321
.0350	.00096211	303
<b>.0359</b>	<b>.00101223</b>	<b>288</b>
.0360	.00101788	286
.0370	.00107521	271
.0380	.00113411	257
.0390	.00119459	244
.0400	.00125664	232
<b>.0403</b>	<b>.00127556</b>	<b>228</b>
.0410	.00132025	221
.0420	.00138544	210
.0430	.00145220	201
.0440	.00152053	192
.0450	.00159043	183
<b>.0453</b>	<b>.00161171</b>	<b>181</b>
.0460	.00166190	175
.0470	.00173494	168
.0480	.00180956	161
.0490	.00188574	155
.0500	.00196350	148
<b>.0508</b>	<b>.00202683</b>	<b>144</b>
.0510	.00204282	143
.0520	.00212372	137
.0530	.00220618	132
.0540	.00229022	127
.0550	.00237583	123
.0560	.00246301	118
<b>.0570</b>	<b>.00255176</b>	<b>114</b>
.0580	.00264208	110
.0590	.00273397	107
.0600	.00282743	103
.0610	.00292247	100
.0620	.00301907	97
.0625	.00306796	95
.0630	.00311725	93
<b>.0640</b>	<b>.00321699</b>	<b>91</b>
.0650	.00331830	88
.0660	.00342119	85
.0670	.00352565	83
.0680	.00363168	80
.0690	.00373928	78
.0700	.00384845	76
.0710	.00395919	74
<b>.0720</b>	<b>.00407150</b>	<b>72</b>
.0730	.00418539	70
.0740	.00430084	68
.0750	.00441786	66
.0760	.00453646	64
.0770	.00465663	63
.0780	.00477836	61
.0790	.00490167	59
.0800	.00502650	58
<b>.0808</b>	<b>.00512758</b>	<b>57</b>
.0900	.00636170	46
<b>.0910</b>	<b>.00650388</b>	<b>45</b>
.0950	.00708820	41
.1000	.00785398	37

Round wire density – 0.286 pounds per cubic inch. See reverse side for multiplication factors for other materials

### Multiplying Factors for 304/316 Footage Conversion Chart

ALLOYS		
Factor	Type	Density
.9408	35N LT <sup>®</sup>	.304
.9408	MP35N <sup>®</sup>	.304
.8588	L-605	.333
.9533	FWM 1058 <sup>®</sup>	.300
.9533	Conichrome <sup>®</sup>	.300
1.2275	Nitinol	.233
.8910	Nickel 200	.321
.8563	Hastelloy <sup>®</sup> B	.334
.8855	Hastelloy <sup>®</sup> C	.323
.9630	Hastelloy <sup>®</sup> X	.297
.9597	Rene 41	.298
.9408	Inconel <sup>®</sup> 600	.304
.9377	Inconel <sup>®</sup> 625	.305
.9533	Inconel <sup>®</sup> X-750	.300
.9727	Waspaloy <sup>®</sup>	.294
1.0000	A-286	.286
1.0250	420	.279
1.0214	Custom <sup>®</sup> 455	.280
.9794	20Cb-3 <sup>®</sup>	.292
1.0000	17-7PH <sup>®</sup>	.286
1.0035	22-12-5 (XM-19)	.285
1.0362	BioDur <sup>®</sup> 108	.276
.9565	FWM <sup>™</sup> 1537	.299

METALS		
Factor	Type	Density
.3690	Platinum (Pt)	.775
1.7546	Titanium (Ti)	.163
.9930	Iron (Fe)	.284
.8909	Copper (Cu)	.321
.8909	Nickel (Ni)	.321
.7546	Silver (Ag)	.379
.4755	Tantalum (Ta)	.600
.4097	Tungsten (W)	.698
.4097	Gold (Au)	.698
1.2118	Zirconium (Zr)	.236
COMPOSITES		
Factor	Type	Density
.8854	MP-DFT <sup>®</sup> 25%Ag	.323
.8693	MP-DFT <sup>®</sup> 33%Ag	.329
.7566	MP-DFT <sup>®</sup> 25%Ta	.378
.7114	MP-DFT <sup>®</sup> 33%Ta	.402
.9256	316L-DFT <sup>®</sup> 25%Ag	.309
.9022	316L-DFT <sup>®</sup> 33%Ag	.317
.7836	316L-DFT <sup>®</sup> 25%Ta	.365
.7333	316L-DFT <sup>®</sup> 33%Ta	.390
.9347	DBS <sup>®</sup> (7) 316-Ag	.306
.9138	DBS <sup>®</sup> (49) 316-Ag	.313

### Flat Wire Conversion Factors

The first column is width divided by thickness. The factor is to be used to calculate cross-sectional area (i.e. .003 ÷ .010 Flatwire; .010 ÷ .003 = 3.3; look up 3.3 in the first column to get .984 factor in the second column; .003 x .010 x .984 = .0000295; this is the cross-sectional area. Look up the cross-sectional area on the opposing page for the feet per pound.

Width/Thickness	Factor
1.1	.836
1.2	.867
1.3	.890
1.4	.907
1.5	.920
1.6	.930
1.7	.939
1.8	.946
1.9	.952
2.0	.957
2.1	.961
2.2	.964
2.3	.968
2.4	.970
2.5	.973
2.6	.975
2.7	.977
2.8	.978
2.9	.980
3.0	.981
3.1	.982
3.2	.983
3.3	.984
3.4	.985
3.5	.986
3.6	.987
3.7-3.8	.988
3.9-4.0	.989
4.1-4.2	.990
4.3-4.4	.991
4.5-4.7	.992
4.8-5.0	.993
5.1-5.5	.994
5.6-6.0	.995
6.1-6.9	.996
7.0-8.1	.997
8.2-10.0	.998

### Mechanical Properties for Types 302, 304, and 316L

Finished Diameter (Inches)	Type 302 and 304				Type 316LVM	
	Spring Temper (KSI)		Hyten (KSI)		Spring Temper (KSI)	
	Min	Max	Min	Max	Min	Max
Up to .009 in.	325	355	425	455	245	275
Over .009 to .010	320	350	420	450	245	275
Over .010 to .011	318	348	418	448	240	270
Over .011 to .012	316	346	410	440	240	270
Over .012 to .013	314	344	405	435	240	270
Over .013 to .014	312	342	400	430	240	270
Over .014 to .015	310	340	395	425	240	270
Over .015 to .016	308	338	390	420	235	265
Over .016 to .017	306	336	386	416	235	265
Over .017 to .018	304	334	384	414	235	265
Over .018 to .020	300	330	382	412	235	265
Over .020 to .022	296	326	380	410	235	265
Over .022 to .024	292	322	-	-	235	265
Over .024 to .026	291	320	-	-	235	265
Over .026 to .028	289	318	-	-	235	265
Over .028 to .031	285	315	-	-	235	265
Over .031 to .034	282	310	-	-	235	265
Over .034 to .037	280	308	-	-	235	265
Over .037 to .041	275	304	-	-	235	265
Over .041 to .045	272	300	-	-	230	260
Over .045 to .050	267	295	-	-	230	260
Over .050 to .054	265	293	-	-	225	255
Over .054 to .058	261	289	-	-	220	250
Over .058 to .063	258	285	-	-	220	250
Over .063 to .070	252	281	-	-	215	245
Over .070 to .075	250	278	-	-	215	245
Over .075 to .080	246	275	-	-	210	240
Over .080 to .087	242	271	-	-	205	235
Over .087 to .095	238	268	-	-	205	235
Over .095 to .105	232	262	-	-	200	230

The minimum tensile strength for straightened and cut lengths shall be 90% of the values listed in the table. Spring Temper values are in accordance with ASTM A-313.

# Round Wire Specifications

## Permitted Variations in Size of Cold-Finished Round Bars

Specified Size, in. [mm]	Permitted Variations from from Specified Size, in. [mm] <sup>A,B</sup>	
	Over	Under
1/16 to 5/16 (1.50 to 8.00), excl	0.001 [0.03]	0.001 [0.03]
5/16 to 1/2 [8.00 to 13.00], excl	0.0012 [0.04]	0.0015 [0.04]
1/2 to 1 [13.00 to 25.00], excl	0.002 [0.05]	0.002 [0.05]
1 to 1 1/2 [25.00 to 38.00], excl	0.0025 [0.06]	0.0025 [0.06]
1 1/2 to 3 1/4 [38.00 to 83.00], incl <sup>C</sup>	0.003 [0.008]	0.003 [0.08]
3 1/4 to 4 [83.00 to 100], incl <sup>C</sup>	0.005 [0.13]	0.005 [0.13]

<sup>A</sup> Unless otherwise specified, size tolerances are over and under as shown in the above table. When required, however, they may be specified all over and nothing under, or all under and nothing over, or any combination of over and under, if the total spread in size tolerance for a specified size is not less than the total spread shown in the table.

<sup>B</sup> When it is necessary to heat treat or heat treat and pickle after cold finishing, size tolerances are double those shown in the table.

<sup>C</sup> Cold-finished bars over 4 in. [100 mm] in diameter are produced; size tolerances for such bars are not included herein.

## Permissible Variations In Diameter and Out-of-Round for Round Wire

Specified Diameter, in. [mm]	Diameter Tolerances, in. [mm]	
	Over	Under
1.000 [25.00] and over	0.0025 [0.06]	0.0025 [0.06]
Under 1.000 [25.00] to 0.500 [13.00]	0.002 [0.05]	0.002 [0.05]
Under 0.5000 [13.00] to 0.3125 [8.00] incl	0.0015 [0.04]	0.0015 [0.04]
Under 0.3125 [8.00] to 0.0440 [1.00] incl	0.001 [0.03]	0.001 [0.03]
Under 0.0440 [1.00] to 0.0330 [0.80] incl	0.0008 [0.02]	0.0008 [0.02]
Under 0.0330 [0.80] to 0.0240 [0.60] incl	0.0005 [0.015]	0.0005 [0.015]
Under 0.0240 [0.60] to 0.0120 [0.30] incl	0.0004 [0.010]	0.0004 [0.010]
Under 0.0120 [0.30] to 0.0080 [0.20] incl	0.0003 [0.008]	0.0003 [0.008]
Under 0.0080 [0.20] to 0.0048 [0.12] incl	0.0002 [0.005]	0.0002 [0.005]
Under 0.0048 [0.12] to 0.0030 [0.08] incl	0.0001 [0.003]	0.0001 [0.003]

The maximum out-of-round for round wire is one half of the total size tolerance given in this table.

When it is necessary to heat treat or heat treat and pickle after cold finishing, size tolerances are double those shown above for sizes 0.024 in. [0.06 mm] and over. Size tolerances have not been evolved for wire produced by cold rolling.

These tolerances apply to small diameter straightened and cut wire (sizes below approximately 1/16 in.). Refer to Table "Permitted Variations in Size of Cold-Finished Round Bars" (above).

# 304V Stock Program

Fort Wayne Metals' stock program quickly supplies you with small quantities of 304V wire. Master spools of 304V wire are available for next day shipping and custom spooling in a week. Contact your Customer Service Associate at (260) 747.4154 with a purchase order or a major credit card number.

## Available Flat Wire

Size	Tensile	Spool	Nom. Wt.
.005" x .015"	305 – 335	DIN125	3.00 Lb.
.004" x .015"	310 – 340	DIN125	3.00 Lb.
.005" x .010"	310 – 340	DIN125	3.00 Lb.
.004" x .010"	310 – 340	DIN125	3.00 Lb.
.003" x .010"	310 – 340	DIN125	3.00 Lb.
.001" x .005"	300 – 350	DIN100	0.68 Lb.
.001" x .003"	300 – 350	DIN100	0.40 Lb.
.0007" x .003"	285 – 365	DIN100	0.22 Lb.
.0005" x .003"	285 – 365	DIN100	0.16 Lb.
.0005" x .0025"	285 – 365	DIN100	0.13 Lb.

The lead-time is next day shipment of spooled material and a five working day lead-time for material that needs respooled onto bobbins.

## Available Round Wire

Size	Tensile	Spool	Nom. Wt.
.001"	325-355	2.5X3	.25 Lbs.
.002"	325-355	2.5x3	.50 Lbs.
.003"	325-355	2.5x3	.50 Lbs.
.004"	325-355	4.5x3	1.0 Lbs.
.005"	325-355	6x3.5	2.5 Lbs.
.006"	325-355	6x3.5	2.5 Lbs.
.007"	325-355	6x3.5	3.0 Lbs.
.008"	325-355	6x3.5	3.0 Lbs.
.009"	325-355	6x3.5	3.0 Lbs.
.010"	320-350	6x3.5	5.0 Lbs.
.011"	318-348	6x3.5	5.0 Lbs.
.012"	316-346	6x3.5	5.0 Lbs.
.013"	314-344	6x3.5	5.0 Lbs.
.014"	312-342	6x3.5	5.0 Lbs.
.015"	310-340	6x3.5	5.0 Lbs.
.016"	308-338	6x3.5	5.0 Lbs.
.017"	306-336	6x3.5	5.0 Lbs.
.018"	304-334	6x3.5	5.0 Lbs.
.019"	300-330	6x3.5	5.0 Lbs.
.020"	300-330	8X6	5.0 Lbs.



# FORT WAYNE METALS

Turning knowledge into solutions.

## HEADQUARTERS:

9609 Ardmore Avenue  
Fort Wayne, Indiana 46809  
PHN 260.747.4154  
FAX 260.747.0398  
EMAIL [info@fwmetals.com](mailto:info@fwmetals.com)



## FORT WAYNE METALS

IRELAND LIMITED

## EUROPEAN OFFICES:

Production and sales office:  
Fort Wayne Metals Ireland Limited  
Drumconlon, Moneen Road  
PHN +353 94 904 3500  
FAX +353 94 904 3555  
EMAIL [ireland@fwmetals.com](mailto:ireland@fwmetals.com)

### Sales office:

Aalsterweg 110D  
5615 Eindhoven  
The Netherlands  
PHN +31 40212 7828  
FAX +31 40212 7864

## CHINESE OFFICE:

Fort Wayne Metals Shanghai Office  
Suite B, 22nd Floor  
1800 Zhongshan West Road  
Shanghai China 200235  
PHN 86-21-6440-3170  
FAX 86-21-6440-3173

[fwmetals.com](http://fwmetals.com)

